

SP-2

Call Point Protector

- Polycarbonate construction
- Surface mount
- Can retrofit over existing device
- **Red and green covers supplied**
- Built-in sounder

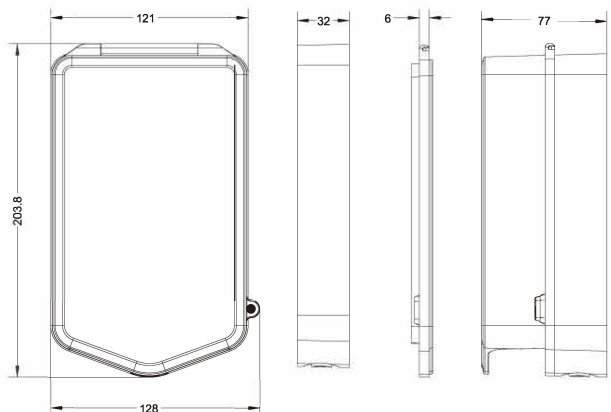
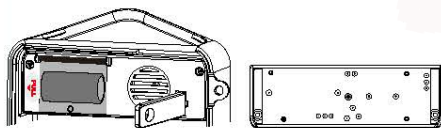
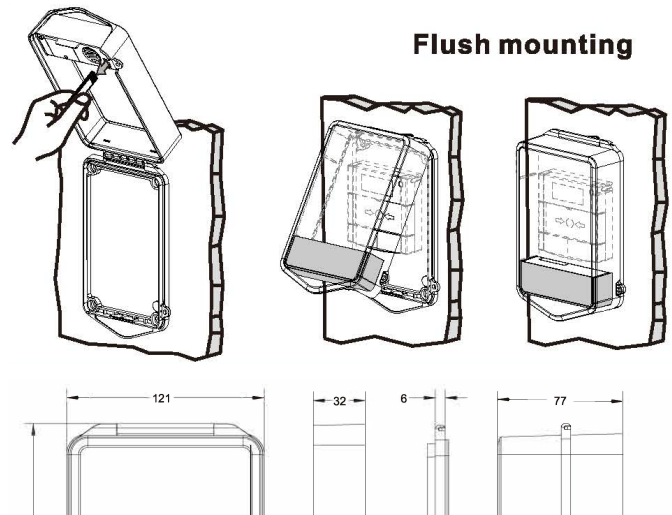
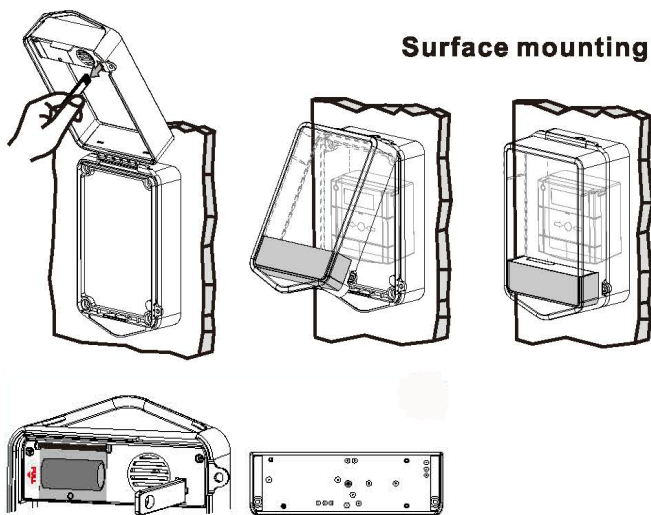

Standby current: 15µA

Volume
Low: 87dB@1m, 8mA
High: 94dB@1m, 20mA

Battery:
Primary Lithium Battery
3V, 1500mAh

SPECIFICATION

- Protective cover helps prevent malicious or accidental false fire alarms
- Three year guarantee against breakage
- Operating temperature: -40~49°C (-40 to 120°F).
- Break seal option for added security.
- Available with or without a 96dB integral sounder powered by a 3V lithium battery.