

Akuvox Smart
Intercom



R26C



R26P

R26 Series Door Phone User Manual

About This Manual

Thank you for choosing Akuvox's R26 series door phone. This manual is intended for end users, who need to properly configure the door phone. This manual is applicable to 26.0.3.xx version, and it provides all functions' configurations of R26C/P. Please visit Akuvox forum or consult technical support for any new information or latest firmware.

Note: Please refer to universal abbreviation form in the end of manual when meet any abbreviation letter.

Content

1. Product Overview.....	1
1.1. Product Description.....	1
1.2. Connector Introduction.....	2
1.3. LED Status Information.....	3
2. Daily Use.....	4
2.1. Make a Call.....	4
2.2. Receive a Call.....	4
2.3. Unlock by RFID Card (Optional).....	4

1. Product Overview

1.1. Product Description

Akuvox R26X is a SIP-compliant, hands-free one button video outdoor phone. It can be connected with users Akuvox indoor monitors for remote access controlling and monitoring. Users can operate the indoor phone to communicate with visitors via voice and video, and use RFID cards to unlock the door (R26C only). It's applicable in villas, offices and so on.

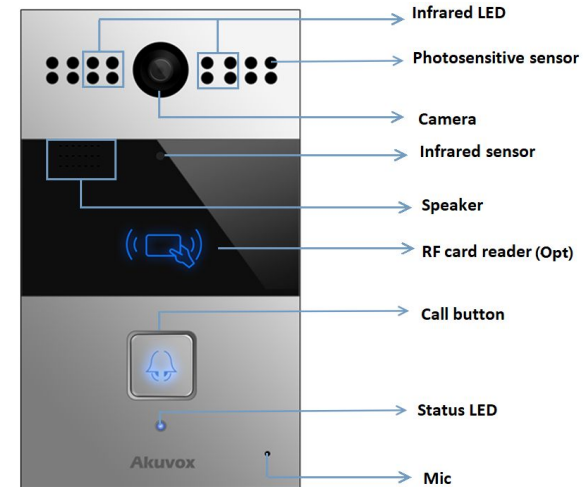

Figure 1.1 Product description

1.2. Connector Introduction

Ethernet (POE): Ethernet (POE) connector, which can provide both power and network connection.

12V/GND: External power supply terminal if POE is not available.

RS485A/B: RS485 terminal.

DOORA/B: Trigger signal input terminal.

RelayA/B (NO/NC/COM): Relay control terminal.

Note: The general door phone interface diagram is only for reference.

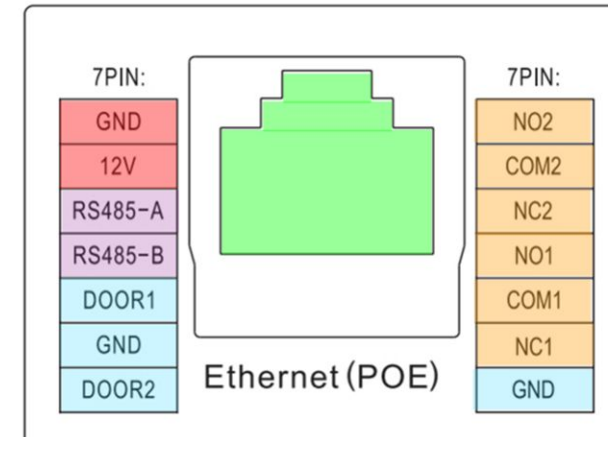

Figure 1.2-1 R26's interface

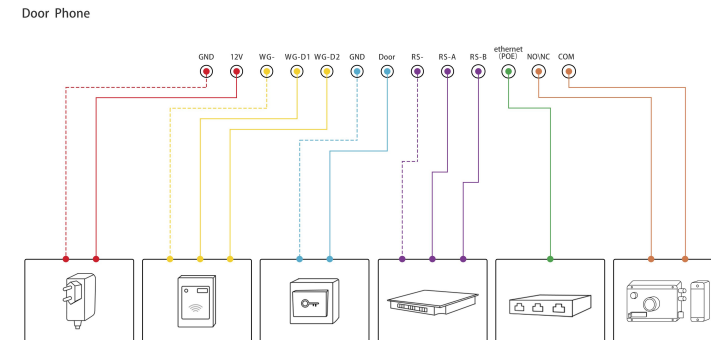

Figure 1.2-2 General interface

1.3. LED Status Information

LED Status		Description
Blue	Always on	Normal status
	Flashing	Calling
Red	Flashing	Network is unavailable
Green	Always on	Talking on a call
	Flashing	Receiving a call
Pink	Flashing	Upgrading

2. Daily Use

2.1. Make a Call

Press the call button to dial out the predefined number or IP address. If LED turns green, it means the call has been answered.

2.2. Receive a Call

Users can use phone or indoor monitor to call R26X and R26X will answer it automatically by default. If auto answer function is disabled, pressing call button to answer incoming call.

2.3. Unlock by RFID Card (Optional)

Place the predefined RFID card on the card reader. The door phone will announce “the door is now opened” and unlock the door. 13.56MHz RF card is supported on R26C.

Abbreviations

ACS: Auto Configuration Server

Auto: Automatically

AEC: Configurable Acoustic and Line Echo Cancelers

ACD: Automatic Call Distribution

Autop: Automatic Provisioning

AES: Advanced Encryption Standard

BLF: Busy Lamp Field

COM: Common

CPE: Customer Premise Equipment

CWMP: CPE WAN Management Protocol

DTMF: Dual Tone Multi-Frequency

DHCP: Dynamic Host Configuration Protocol

DNS: Domain Name System

DND: Do Not Disturb

DNS-SRV: Service record in the Domain Name System

FTP: File Transfer Protocol

GND: Ground

HTTP: Hypertext Transfer Protocol

HTTPS: Hypertext Transfer Protocol Secure

IP: Internet Protocol

ID: Identification

IR: Infrared

LCD: Liquid Crystal Display

LED: Light Emitting Diode

MAX: Maximum

POE: Power Over Ethernet

PCMA: Pulse Code Modulation A-Law

PCMU: Pulse Code Modulation μ -Law

PCAP: Packet Capture
PNP: Plug and Play
RFID: Radio Frequency Identification
RTP: Real-time Transport Protocol
RTSP: Real Time Streaming Protocol
MPEG: Moving Picture Experts Group
MWI: Message Waiting Indicator
NO: Normal Opened
NC: Normal Connected
NTP: Network Time Protocol
NAT: Network Address Translation
NVR: Network Video Recorder
ONVIF: Open Network Video Interface Forum

SIP: Session Initiation Protocol
SNMP: Simple Network Management Protocol
STUN: Session Traversal Utilities for NAT
SMTP: Simple Mail Transfer Protocol
SDMC: SIP Devices Management Center
TR069: Technical Report069
TCP: Transmission Control Protocol
TLS: Transport Layer Security
TFTP: Trivial File Transfer Protocol
UDP: User Datagram Protocol
URL: Uniform Resource Locator
VLAN: Virtual Local Area Network
WG: Wiegand

Contact us

For more information about the product, please visit us at www.akuvox.com or feel free to contact us by

Sales email: sales@akuvox.com

Technical support email: techsupport@akuvox.com

Telephone: +86-592-2133061 ext.7694/8162

We highly appreciate your feedback about our products.

