

INSTRUCTIONS Read all instructions before starting installation

PACK CONTENTS

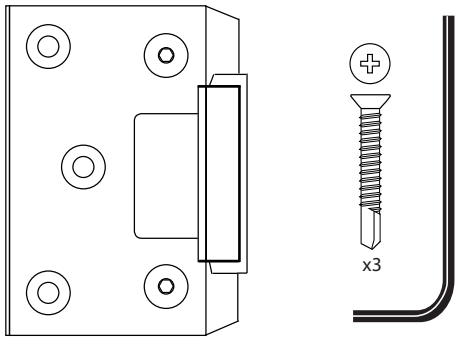

DOOR LATCH POSITION

As shown in Figure 1, there must be a 1mm gap between the door latch and the front face of strike keeper to prevent the door from exerting pressure on the keeper when door is closed.

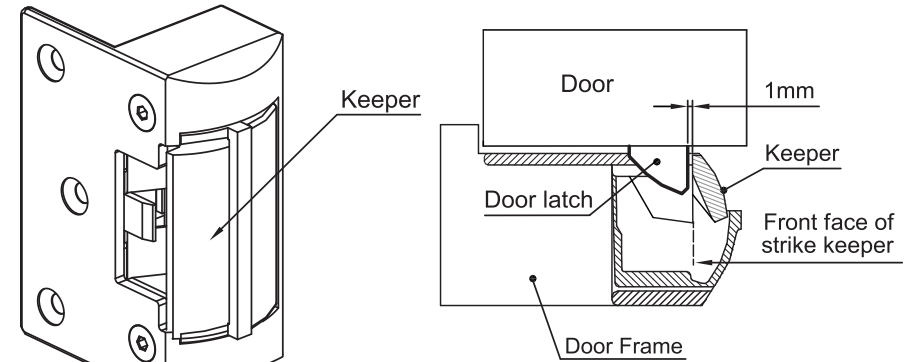

Figure 1

MOUNTING STEPS OF STRIKE

- 1 Position the strikes against the frame, mark and drill the hole sizes as shown on Figure 2 and 3.
- 2 Drill cable exit hole on door frame.
- 3 Make sure electrical connections are followed correctly.
- 4 When the door is closed, ensure that there is no pressure on the front face of strike keeper.

POWER INPUT 12 VDC or 24VDC SUPPLY

Note: There's no polarity on power input, AL150 is not equipped with DSS sensor.

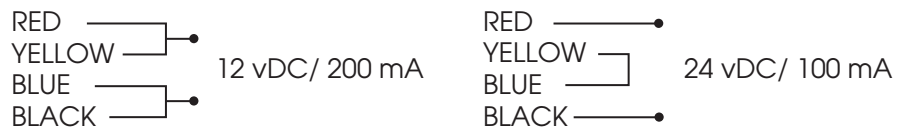

DSS (Door Status Sensor), BLACK (COM), BLUE (NO), ORANGE (NC)
DSS contact rating: max. current 100 mA, max. voltage 30 vDC

INSTALL ON TIMBER DOOR FRAME

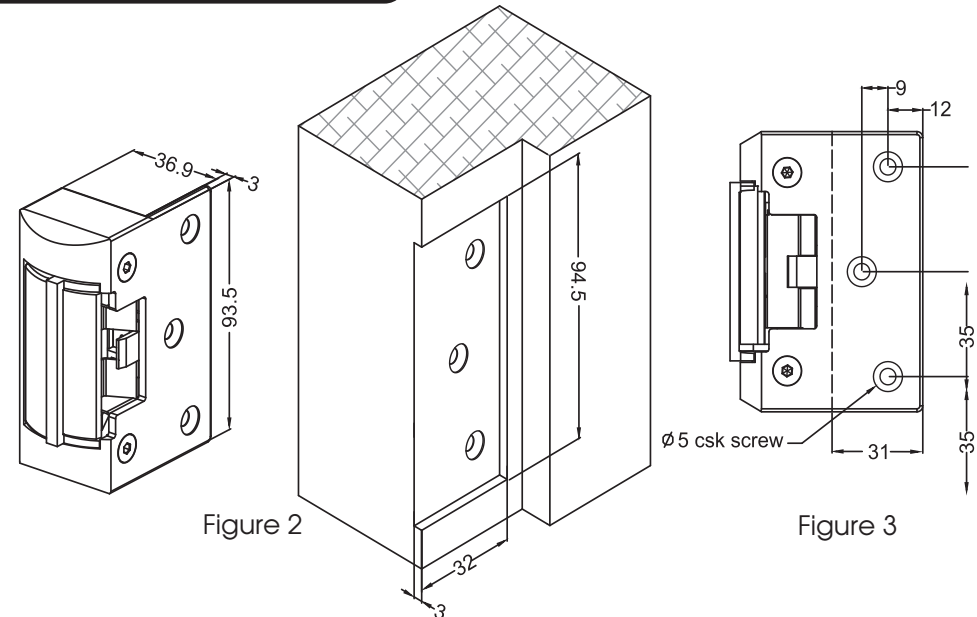

Figure 2

Figure 3

CONVERSION: POWER TO LOCK <=> POWER TO OPEN

Figure 4A

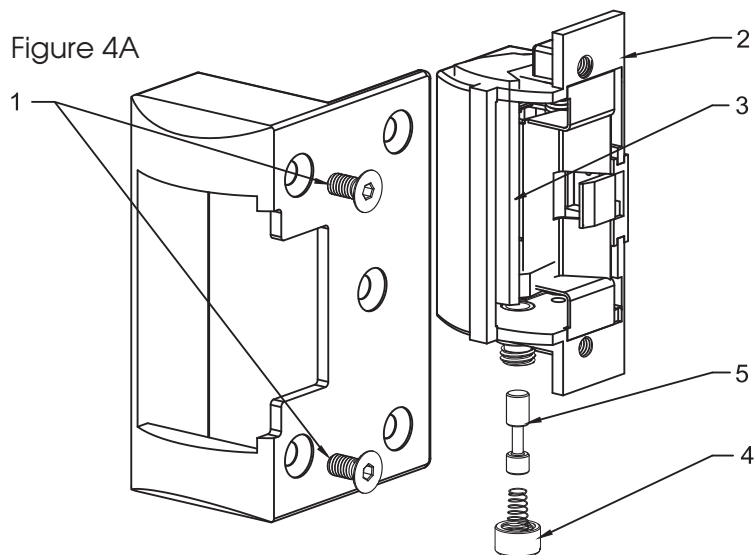
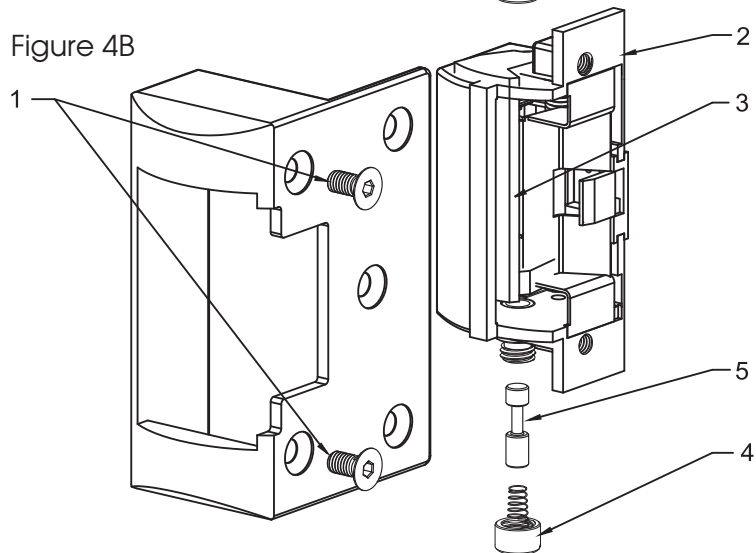

Figure 4B



WARNING:

Do not press on the keeper to release when the spring screw is not totally secured in position, this will cause damage to the spring barbell. When changing function, micro switch will spring out.

Procedures to convert Power to Open (Figure 4B) to Power to Lock (Figure 4A):

- Step 1: Remove the two cover plate screws.
- Step 2: Remove the lock body from the cover housing.
- Step 3: Remove the spring screw from the end part of the strike body.
- Step 4: Remove the Barbell and replace in reverse position with long part in and short part out.
- Step 5: Replace the spring screw.
- Step 6: Refit the lock body into the cover housing and screw in the two cover plate screws.

Procedures to convert Power to Lock (Figure 4A) to Power to Open (Figure 4B):

- Step 1: Remove the two cover plate screws.
- Step 2: Remove the lock body from the cover housing.
- Step 3: Remove the spring screw from the end part of the strike body.
- Step 4: Remove the Barbell and replace in position with short part in and long part out.
- Step 5: Replace the spring screw.
- Step 6: Refit the lock body into the cover housing and screw in the two cover plate screws.

ELECTRIC STRIKE MAINTENANCE

Maintenance should be carried out every 6 months, or higher for heavy duty door traffic.

Electric strikes should be fitted exactly in accordance with the Alpro fixing instructions, ensuring and maintaining all relevant door gaps and clearances.

Under no circumstances use a spray lubricant, as this type of solvent can damage electronics. Electrical parts with the strike need no maintenance.

If required fit a protective diode as close to the coil as possible to protect the system from transient peaks.

Ensure on a regular basis the whole of the door system is checked (lock case, door closer, strike plate, handles etc.) to ensure the desired level of door operation and security is being maintained.

PLEASE NOTE:

The warranty for the strike is void if:

The strike is assembled incorrectly

Parts fitted to the strike which are not approved Alpro Parts

The strike is incorrectly wired

There is incorrect voltage applied to the strike

Alpro electric strikes should be installed by suitably qualified engineers