

# Installation Instructions

## S361TERM - Relay termination box

This termination box is purely a junction box which provides two sets of terminals each labelled as relay contacts. The two sets of terminals are joined together to allow for easy connection between a relay of one system and another system. An earth terminal is also provided for convenient termination of an incoming mains cable. As the enclosure is plastic, no earth connection is required.

**The enclosures are supplied un-labelled.** The decal (included) has a clear window 10mm x 46mm. The area under the decal is 12mm wide to take standard labelling machine tape. The window is free from adhesive, nevertheless, it is wise to maintain cleanliness and avoid fingerprints on the inside of the window. If a labelling machine is not available a paper label can be used and examples are given below complete with cutting and folding lines. If the text you require is not shown here then it is a fairly simple matter to make one with a word processing or graphics programme. The dimensions here are given to help you.

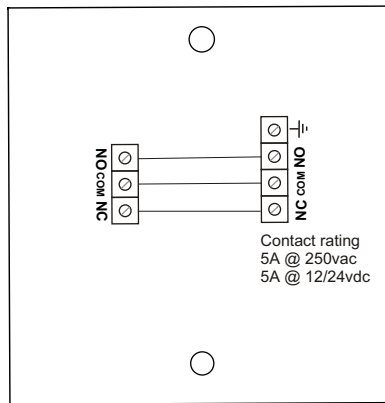

Terminals will accept cable sizes up to 2.5mm<sup>2</sup>, however 1mm<sup>2</sup> is recommended

Fold	<b>Mains Relay</b>	Fold
Fold	<b>Mains Relay Terminals</b>	Fold
Fold	<b>Lighting Relay</b>	Fold
Fold	<b>Lighting Relay Terminals</b>	Fold
Fold	<b>Fire Relay</b>	Fold
Fold	<b>Fire Relay Terminals</b>	Fold
Fold	<b>Alarm Relay</b>	Fold
Fold	<b>Alarm Relay Terminals</b>	Fold
Fold	<b>Shutter Relay</b>	Fold
Fold	<b>Shutter Relay Terminals</b>	Fold
Fold	<b>Lock Relay</b>	Fold
Fold	<b>Lock Relay Terminals</b>	Fold

Before applying decal fold paper label and insert through slots

Ensure all surfaces are clean and free from dust etc..

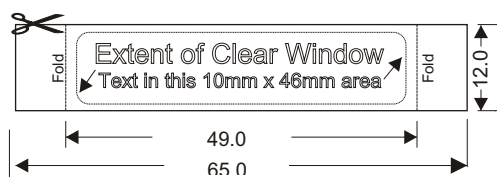
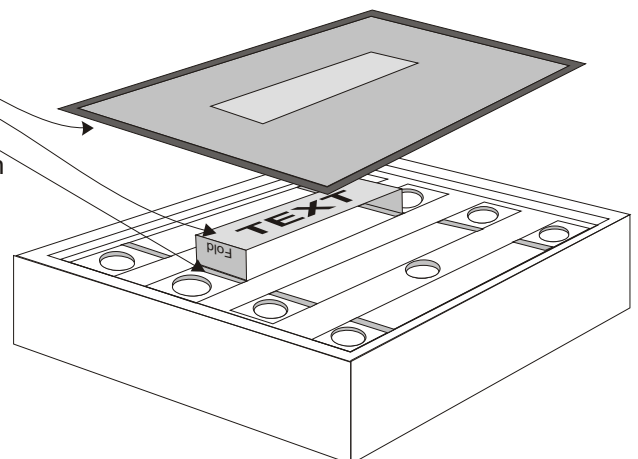

**Hoyles Electronic Developments Ltd**

T. 01744 886600 F. 01744 886607 E. sales@hoyles.com W. www.hoyles.com