

## TFT LCD MONITOR

---

### USER MANUAL

#### HMDE Series

L104AKL L121AKL

L152AVL L156HDL

L172AVL L185AVL

L192AVL L215HDL

L220AVL L240HDL

L270HDL L320HDL

L420HDL



## Table Of Contents

Table of contents/ Warning.....	2
Precautions .....	3
About this user manual / Items included in the delivery .....	4
1. IR-remote control .....	5
2. LCD monitor mounting .....	7
3. Monitor controls .....	9
4. Connections.....	10
5. Monitor settings via OSD menu .....	12
5.1 Picture .....	12
5.2 Sound .....	12
5.3 OSD Setup .....	13
5.4 Advance .....	13
5.5 PIP .....	14
5.6 PC .....	14
5.7 Geometry .....	14
6. Special features .....	15
7. Technical specifications .....	16

### Warning:

TO REDUCE THE RISK OF FIRE OR ELECTRIC SHOCK, DO NOT EXPOSE THIS PRODUCT TO RAIN OR MOISTURE.

DO NOT INSERT ANY METALLIC OBJECT THROUGH VENTILATION GRILLS.

### **Caution:**

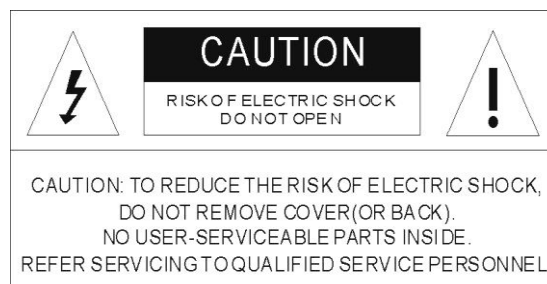

### **Explanation of Graphical Symbols**



**Danger:** This symbol is intended to alert the user to the presence of un-insulated "dangerous voltage" within the product's enclosure that may be of sufficient magnitude to constitute a risk of electric shock to a person.



**Warning:** This symbol is intended to alert the user to the presence of important operating and maintenance (servicing) instructions in the literature accompanying the appliance.

## **Precautions**

### **Safety-----**

Should any liquid or solid object fall into the cabinet, unplug the unit and have it checked by the qualified personnel before operating it any further.

Unplug the unit from the wall outlet if it is not going to be used for several days or more. To disconnect the cord, pull it out by the plug. Never pull the cord itself.

Allow adequate air circulation to prevent internal heat built-up. Do not place the unit on surfaces (rugs, blankets, etc.) or near materials (curtains, draperies) that may block the ventilation holes.

### **Safety Precautions**

#### **Federal Communications Commission (FCC) Statement**

This Equipment has been tested and found to comply with the limits for a Class B digital device, pursuant to Part 15 of the FCC rules. These limits are designed to provide reasonable protection against harmful interference in a residential installation. This equipment generates, uses and can radiate radio frequency energy and, if not installed and used in accordance with the instructions, may cause harmful interference to radio communications. However, there is no guarantee that interference will not occur in a particular installation.

If this equipment does cause harmful interference to radio or television reception, which can be determined by turning the equipment off and on, the user is encouraged to try to correct the interference by one or more of the following measures:

- Reorient or relocate the receiving antenna.
- Increase the separation between the equipment and receiver.
- Connect the equipment into an outlet on a circuit different from that to which the receiver is connected.
- Consult the dealer or an experienced radio/TV technician for help.

### **Installation-----**

Do not install the unit in an extremely hot or humid place or in a place subject to excessive dust or mechanical vibration.

The unit is not designed to be waterproof. Exposure to rain or water may damage the unit.

### **Cleaning-----**

Clean the unit with a slightly damp soft cloth. Use a mild household detergent. Never use strong solvents such as thinner or benzene as they might damage the finish of the unit.

Retain the original carton and packing materials for safe transport of this unit in the future.

- You are cautioned that changes or modifications not expressly approved by that party responsible for compliance could void your authority to operate the equipment.

This device complies with Part 15 FCC Rules. Operation is subject to the following two conditions:

- (1) This device may not cause harmful interference.
- (2) This device must accept any interference received including interference that may cause undesired

### **About this user manual**

This manual aims at assisting the user on how to operate the monitors described in this manual.

This manual is subject to rigid quality control. However, no guarantee can be given that mistakes are not present. We reserve the right to make changes to the manual without prior notice.

Before operating the appliance, please read this manual carefully and retain it for further reference. Verify that all appliance items are included in the delivery. Should items be missing, do not operate the appliance and contact your local dealer.

Never attempt to repair the appliance yourself. This should only be done by qualified service personnel.

Improper handling of the appliance will invalidate the warranty.

### **Items included in the delivery**

- 1 x LCD monitor
- 1 x Power supply unit 12 V DC [Except for the 32"/42"]
- 1 x Power cord
- 1 x VGA cable Optional
- 1 x Audio cable Optional
- 1 x IR remote control
- 1 x User manual

## 1. IR remote control

- (1). **Power:**  
Press this button to turn the monitor on/off.
- (2). **Zoom:**  
Press this button to toggle between the different picture formats:  
Full/Zoom/Subtitle/Regular/Panorama
- (3).  **Mute:**  
Press this button to disable the sound.  
Press this button again to turn the sound on again.
- (4). **Freeze:**  
Press this button to freeze the picture.  
Press this button again to  
disable the freeze picture and to re-establish  
the normal picture.
- (5). **PC/HD, AV1/AV2, SV:**  
You can select the appropriate signal  
source directly (PC = VGA/DVI).
- (6). **Item:**  
Hot key for OSD adjustments of volume,  
contrast, brightness, hue, saturation, sharpness,  
and Red Green Blue.
- (7). **Source:**  
To switch the video inputs (or sub picture source in pip mode),  
please use the IR remote control included in the delivery  
This button is also used as Enter and Select function in the OSD menu.  
and to confirm your selected settings in the OSD menu.
- (8). **OK / Menu:**  
Press this button to call-up the OSD menu.  
This button is also used as "Exit".  
Note: The menu button is also used to return to the previous menu.
- (9). **Select ▲/▼:**  
Directional buttons up/down.
- (10). **Display:**  
Press this button to call-up screen information such as resolution, signal source, etc.
- (11). **Picture:**  
Press this button to toggle between the different picture modes:  
User, Standard, Movie, Vivid.
- (12). **PIP:**  
Press this button to select the picture-in-picture function. Define the size of the sub picture:  
Small, Medium, Large, POP Full, POP 4:3, OFF.
- (13). **Swap:**  
When in PIP mode, press the swap button to switch the main picture and the sub picture.  
The swap button is only active if you have defined a sub-picture before.
- (14). **Position:**  
When in PIP mode, press the position button to define the position of the sub-picture:  
Either in one of the four screen corners or centred.
- (15). **ID:** Can be control several monitors are installed in the same area.  
In ID mode, press ID key, then input setting number (01~99), to unlock "ID" function.  
**Please press "ID" key again to lock "ID" function.**
- (16). **0~9:** For ID setting number used.

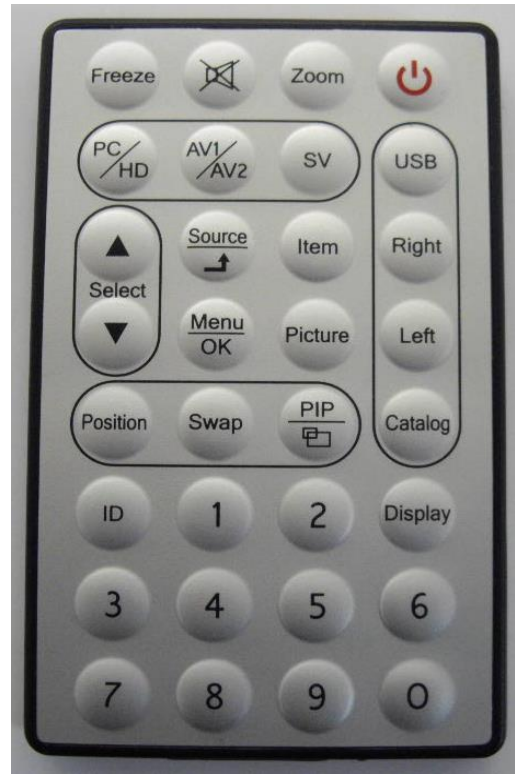

(17). **USB/Right/Left/Catalog:**

1: Press "USB" Key into the JPEG Menu.



2: Press "MENU" Key into the USB Main menu



3: Press "Left" or "Right" key to select the JPEG/MP3/DRIVE function.



4: Press "Up/Down" Key to select play file.



5: Press "Right" Key to into the file

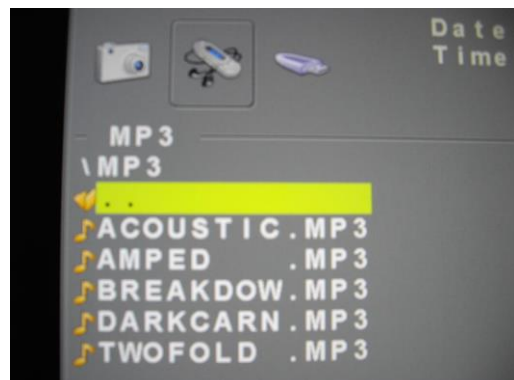

6: Press "Up/Down" Key to select the play file and press Right key to play. And press "Menu" to stop play. Then press "Catalog" return the menu. And press "Menu" into the USB Main menu.



7: Press "PC/HD, AV1/AV2; SV" to exit the USB function.

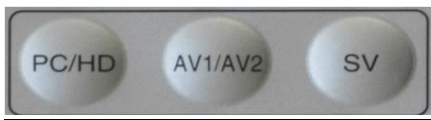

## **2 LCD monitor Mounting Guide**

### **A. Desktop**

Adjust the viewing angle of LCD to fit most comfortable monitoring status.

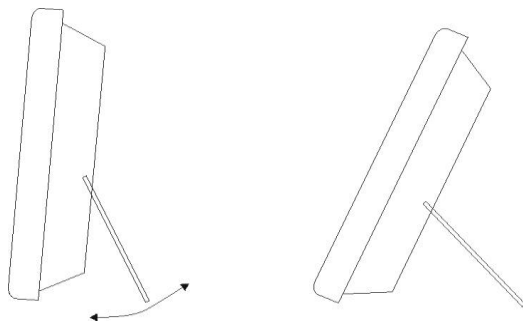

### **B. Wall mount**

Free your space with wall mount design.

Please follow the fix-hole size in back panel to install the LCD to the wall.

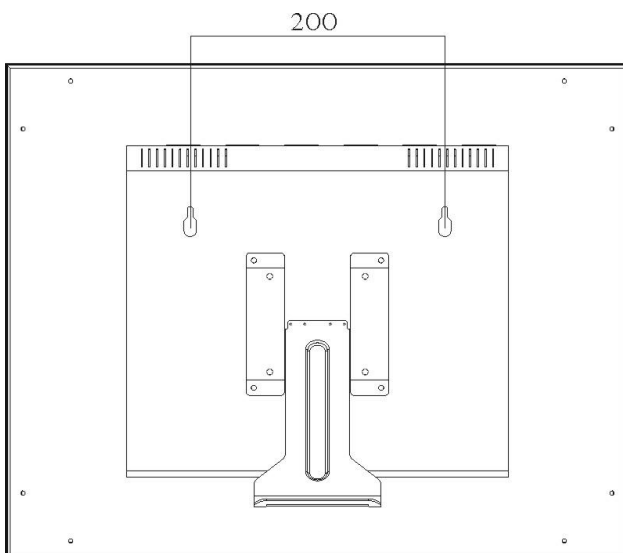

**C. VESA Bracket**

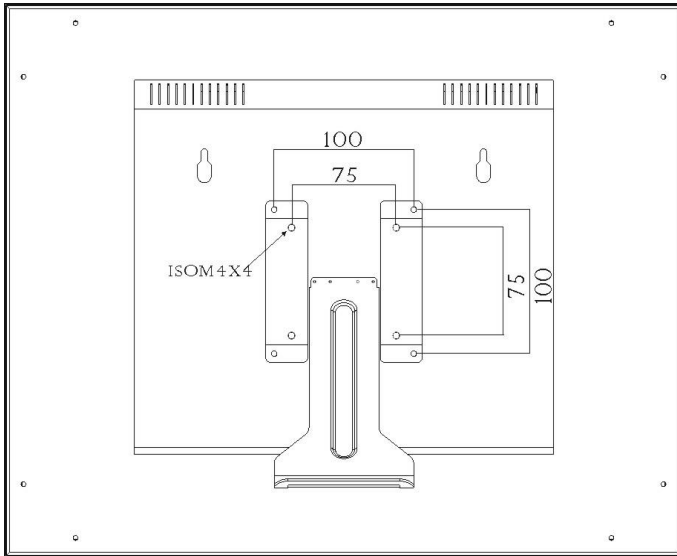

10.4"/12.1"/15"/15.6"/17"/18.5"  
19"/21.5"/22"/24"/27"

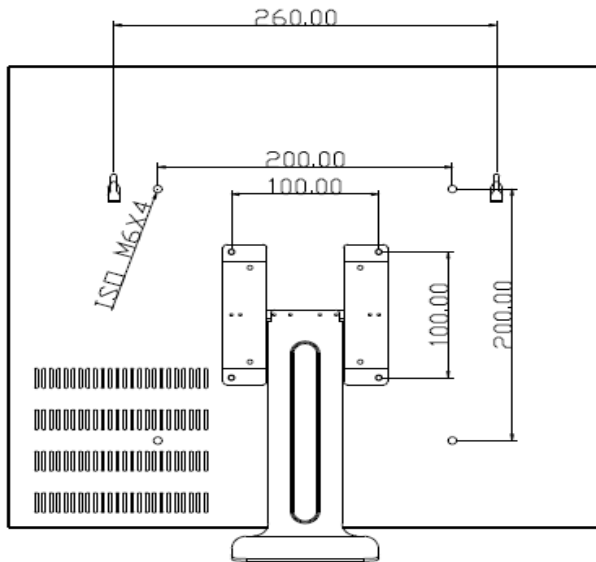

32"

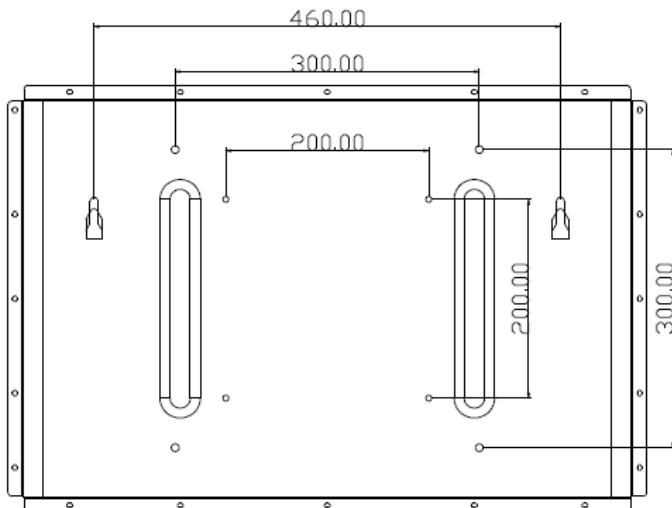

42"



### 3 Monitor controls

15"/17"/19" Plastic

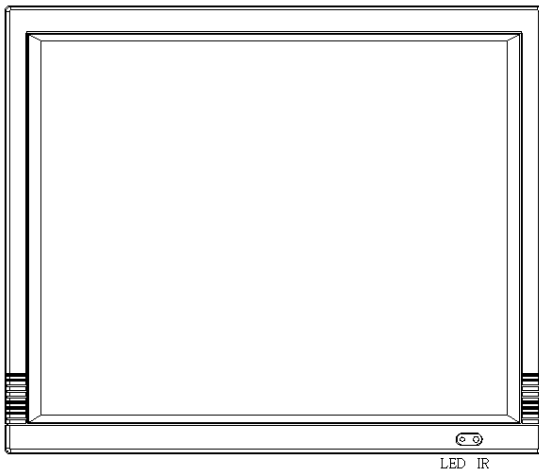

10.4"/12.1"/15"/15.6"/17"/18.5"/19"/21.5"/22"/24"/27" Aluminium

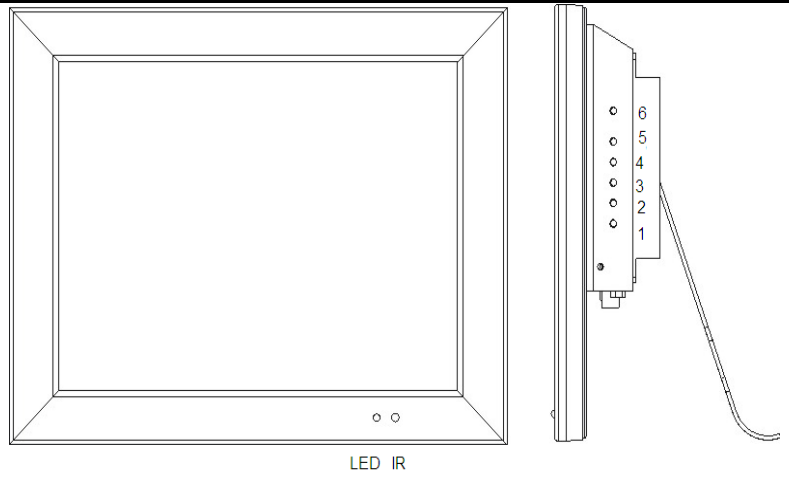

15"/17"/19" Aluminium

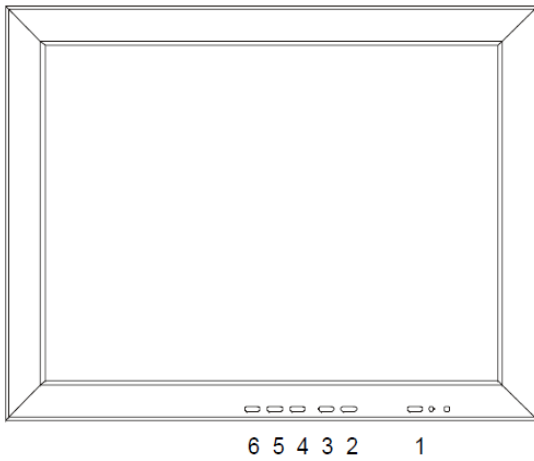

32"/42" Aluminium

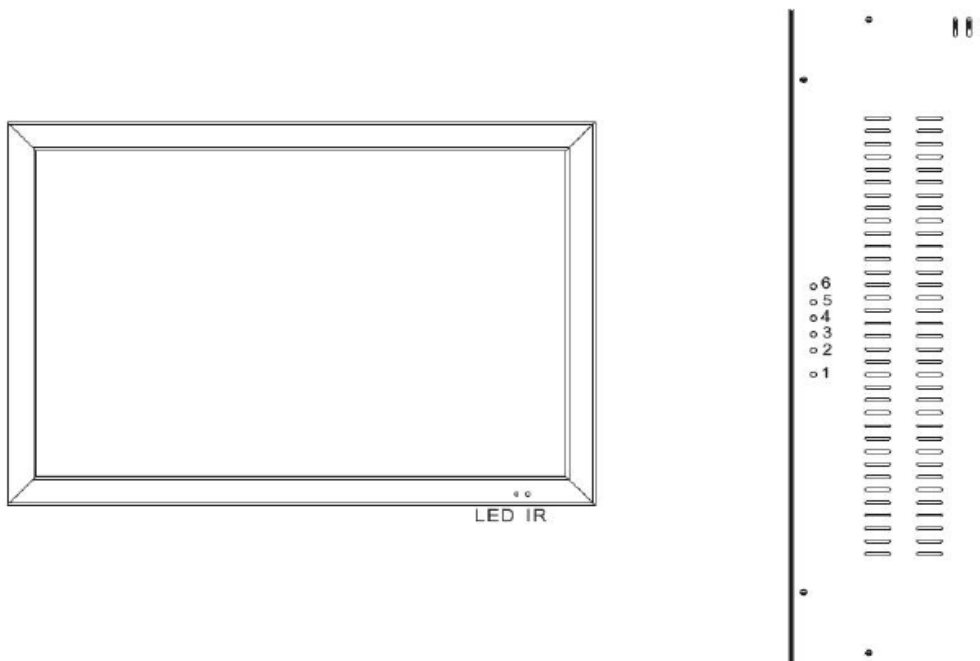

**(1). Power**

Turn the monitor on/off.

LED: Green Monitor on

LED: Red Standby mode (no input signal)

**(2./3). Adjust Up / Down ▲/▼**

Increase or decrease the values in the OSD menu:

Up: Increase the values.

Down: Decrease the values.

**(4). Item/Select:**

Hot key for OSD adjustments of volume, contrast, brightness, hue, saturation, sharpness, and Red, Green, Blue.

**(5). Menu/Function:**

Press this button to call-up the OSD menu.

This button is also used as Exit.

**(6). Source:**

To switch the video inputs, (or sub picture source in pip mode)

This button is also used as Enter and Select function in the OSD menu. and to confirm your selected settings in the OSD menu.

**\*\*\*Push “Menu” and “Item” into key-lock mode, and push again into unlock. \*\*\***

**4. Connections**

10.4” ~ 27”

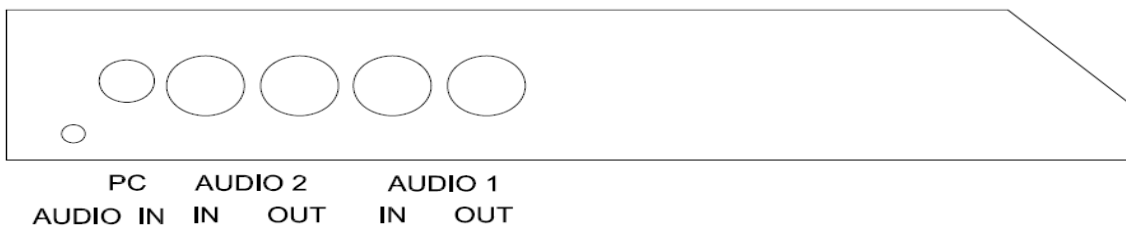
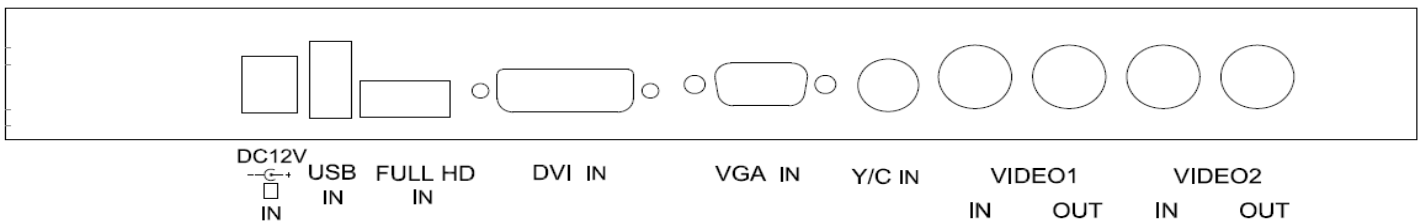

**NOTE:**

Connections of Audio

	Audio 1	Audio 2	PC Audio
AV1	V		
AV2		V	
S-Video		V	
PC			V
DVI			V

32"/42"

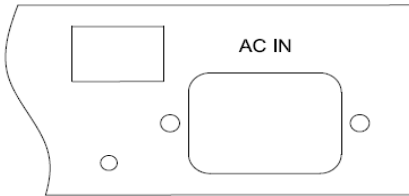
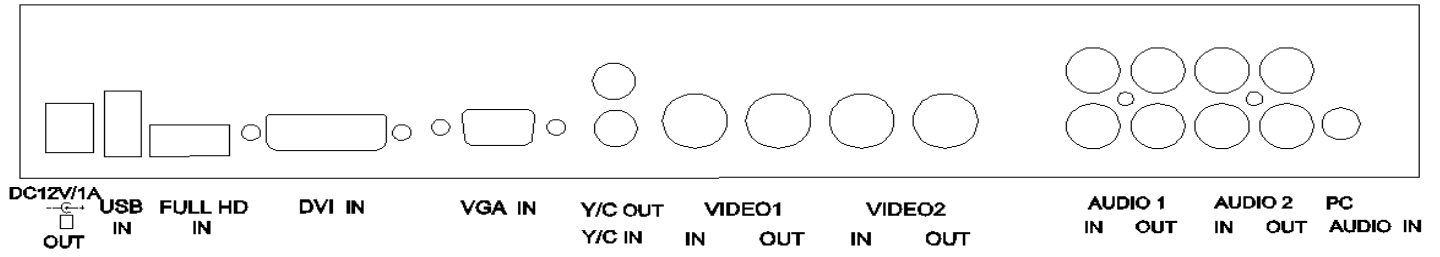

**NOTE:**

Connections of Audio

	Audio 1	Audio 2	PC Audio
AV1	V		
AV2		V	
S-Video		V	
PC			V
DVI			V

## **5. Monitor settings via OSD menu**

Various monitor settings can be made using the OSD menu (On Screen Display).

Press the Menu/OK button to call-up the OSD main menu. Here you can make adjustments to the following items:

- Picture
- Sound
- OSD Setup
  - Advance
  - PIP
- PC (at PC input signal)
  - Geometry (at PC input signal)

Use the ▲/▼ buttons to toggle between the different items.

Press the Source button to select the appropriate item.

### **5.1 Picture**

Use the ▲ ▼ buttons to select adjusts item, and press source button to confirm.

Then use the ▲ ▼ buttons to increase/decrease the values,  
or use “source” button to change the values.

Press the menu button to return to the previous menu item.

<b>Item</b>	<b>Description</b>
Contrast	Use the ▲ ▼ buttons to increase/decrease the screen contrast.
Brightness	Use the ▲ ▼ buttons to increase/decrease the screen brightness.
Hue	Use the ▲ ▼ buttons to increase/decrease the hue.
Saturation	Use the ▲ ▼ buttons to increase/decrease the saturation.
Sharpness	Use the ▲ ▼ buttons to increase/decrease the sharpness.
Colour Temp.	Use the source buttons to select the colour temperature: Normal, Warm, Cool, User.
Picture Mode	Use the source buttons to select the picture mode: User, Standard, Movie, Vivid.
DNR (Noise Reduction)	Use the source buttons to select the level of noise reduction: Off, Low, Medium, High.
DLC	Use the source buttons to change the Black Level Extension on/off.

### **5.2 Sound**

Use the ▲ ▼ buttons to select adjusts item, and press source button to confirm.

Then use the ▲ ▼ buttons to increase/decrease the values,  
or use “source” button to change the values.

Press the menu button to return to the previous menu item.

<b>Item</b>	<b>Description</b>
Volume	Use the ▲ ▼ buttons to adjust the volume.
Mute	Use the source buttons to change the Mute on/off.
Sound Mode	Use the source buttons to adjust the effect: User, Standard, Movie, Vivid.
Bass	Use the ▲ ▼ buttons to adjust the bass. (for R/L Audio in use)
Treble	Use the ▲ ▼ buttons to adjust the treble. (for R/L Audio in use)
Balance	Use the ▲ ▼ buttons to adjust the balance. (for R/L Audio in use)

### 5.3 OSD Setup

Use the ▲ ▼ buttons to select adjusts item, and press source button to confirm. Then use the ▲ ▼ buttons to increase/decrease the values, or use “source” button to change the values. Press the menu button to return to the previous menu item.

Item	Description
Language	Use the source buttons to select the language.
Set ID	Can be control several monitors are installed in the same area. Use the source buttons to into the function. then use up/down key to select you setting the number (01~99), then press menu to exit osd. Press IR remote control “ID” key again to confirm the Set ID function.
Gamma	Use the source buttons to set the gamma values. (0,1,2)
Freeze	Use the source buttons to freeze the picture. Press this button again to disable the freeze picture and to re-establish the normal picture.
OSD Time	Use the ▲ ▼ buttons to setting the OSD menu display time.
OSD Halftone	Use the ▲ ▼ buttons to setting the OSD menu display halftone.
Recall	Press the source button to restore the factory settings.
Obiter (Anti blur)	Use the source buttons to on/off the screen saver: [Screen protector -Anti blur]
Version	Firmware Version

### 5.4 Advance

Use the ▲ ▼ buttons to select adjusts item, and press source button to confirm. Then use the ▲ ▼ buttons to increase/decrease the values, or use “source” button to change the values. Press the menu button to return to the previous menu item.

Item	Description
Scale	Use the source buttons to select the picture size: Full/Zoom/Subtitle/Regular/ /Panorama.
Scan Size	Use the source buttons to select the real image size: Normal/Native
H Position	Use the ▲ ▼ buttons to position the picture horizontally.
V Position	Use the ▲ ▼ buttons to position the picture vertically.

### 5.5 PIP

Use the ▲ ▼ buttons to select adjusts item, and press source button to confirm. Then use the ▲ ▼ buttons to increase/decrease the values, or use “source” button to change the values. Press the menu button to return to the previous menu item.

Item	Description
Multi Window	Use source button to select the picture-in-picture function: PIP, POP Full, POP 4:3 Off.
Sub Source	Use source button to select the source of the PIP sub-picture.
Size	Use source button to set the size of the sub-picture: Small, Medium, Large.
Position	Use source button to define the position of the sub-picture. Note: This function is only active if you have previously defined a sub picture.
Border Colour	Use source button to select the sub-picture background colour: Black /Blue.
Sound Source	Use source button to select the sound source: Main/Sub.
Swap	Use source button to swap the main picture and the sub picture. Note: This function is only active if you have previously defined a sub picture.

## **5.6 PC**

Use the ▲ ▼ buttons to select adjusts item, and press source button to confirm.  
Then use the ▲ ▼ buttons to increase/decrease the values,  
or use “source” button to change the values.  
Press the menu button to return to the previous menu item.

<b>Item</b>	<b>Description</b>
Contrast	Use the ▲ ▼ buttons to increase/decrease the screen contrast.
Brightness	Use the ▲ ▼ buttons to increase/decrease the screen brightness.
Colour Temp	Use the source buttons to select the colour temperature: Normal, Warm, Cool, RGB, User.
Scale	Use the source buttons to select the picture size: Normal/Centre
Auto Adjust	Use the source buttons to Adjust the best image.

## **5.7 Geometry**

Use the ▲ ▼ buttons to select adjusts item, and press source button to confirm.  
Then use the ▲ ▼ buttons to increase/decrease the values,  
or use “source” button to change the values.  
Press the menu button to return to the previous menu item.

<b>Item</b>	<b>Description</b>
H Position	Use the ▲ ▼ buttons to position the picture horizontally.
V Position	Use the ▲ ▼ buttons to position the picture vertically.
Clock	Use the ▲ ▼ buttons to Adjust image distortion appearing as vertical or “noise” on the screen.
Phase	Use the ▲ ▼ buttons to Adjust image distortion appearing as horizontal or “noise” on the screen.

**PC timing:**

Mode	Resolution
1	800 x 600 @ 60
2	800 x 600 @ 72
3	800 x 600 @ 75
4	1024 x 768 @ 60
5	1280 x 1024 @ 60
6	1360 x 768 @ 60
7	1440 x 900 @ 60
8	1920 x 1080 @ 60

**6. Special features**

- Special Video Processor.
- PIP Control Function (Only PC/Video).[Video/Video option]
- Screen protector (Anti-blur /Image auto move).
- NTSC/PAL Auto Switch.
- 3D De-interlace Technology.
- 3D Comb Filter Technology.
- Automatic Colour Control and Colour Killer.
- Luminance transient improvement(LTI),Chrominance transient improvement(CTI)
- Directional zoom engine.
- Video out support auto termination (75 Ohms).
- Build-in 2W speaker, 42" 7W+7W speaker
- Support IR remote controller.
- VESA standard bracket 75/100mm for 10.4"/12.1"/15"/15.6"/17"/18.5"/19"/21.6/22"/24"/27".  
100/200mm for 32". 300mm for 42".

## **7. Technical specifications**

<b>Monitor model</b>	<b>L104AKL</b>	<b>L121AKL</b>
System	PAL / NTSC	
LCD panel	10.4"	12.1"
Visible area (mm)	211.2 x 158.4	246 x 184.5
Picture format	4:3	4:3
Max. resolution	800 x 600	800 x 600
Pixel dot pitch (mm)	0.264 x 0.264	0.3075 x 0.3075
Colours	262 K	262K
Brightness	400 cd/m <sup>2</sup> [LED]	450 cd/m <sup>2</sup> [LED]
Contrast	700 :1	700:1
Response time	30 ms	35 ms
View angle (U/D/L/R)	60/80/80/80	65/75/80/80
Video input/output	2 x / 2 x Composite (BNC)	
S-Video input	1 x 4 Pin Mini Dim	
Full HD input	1 x (A Type)	
Audio input/output	2 x / 2 x (RCA)	
PC input	1 x VGA input (D-Sub 15 pin) 1 x DVI-D input 1 x Audio input	
Speaker	1 x built-in speaker (2 watt)	
3D Comb Filter	Yes	
3D De-Interlace function	Yes	
Picture-in-Picture (PIP)	Yes (video/PC)	
OSD setting	Yes	
Power input	AC 100-240V 50/60Hz, Adapter DC 12V/5A	
Power consumption	Approx. 10 watt	Approx. 12 watt
Dimensions (W*H*D) mm	266 x 214 x 60	300 x 239 x 61
Weight	2.3 kg	2.6 kg
Operating temperature	0° to 40° C	

Subject to technical changes without prior notice. Error excepted.



Monitor model	L152AVL	L156AVL
System	PAL / NTSC	
LCD panel	15"	15.6"
Visible area (mm)	304 x 228	344.2 x 193.5
Picture format	4:3	16:9
Max. resolution	1024 x 768	1366x768
Pixel dot pitch (mm)	0.297 x 0.297	0.252 x 0.252
Colours	16.7M	16.7M
Brightness	250 cd/m <sup>2</sup>	300 cd/m <sup>2</sup> [LED]
Contrast	600 :1	500:1
Response time(Tr/Tf)	6/2 ms	6/2 ms
View angle (U/D/L/R)	80/80/80/80	80/80/85/85
Video input/output	2 x / 2 x Composite (BNC)	
S-Video input	1 x 4 Pin Mini Dim	
Full HD input	1 x (A Type)	
Audio input/output	2 x / 2 x (RCA)	
PC input	1 x VGA input (D-Sub 15 pin) 1 x DVI-D input 1 x Audio input	
Speaker	1 x built-in speaker (2 watt)	
3D Comb Filter	Yes	
3D De-Interlace function	Yes	
Picture-in-Picture (PIP)	Yes (video/PC)	
OSD setting	Yes	
Power input	AC 100-240V 50/60Hz, Adapter DC 12V/5A	
Power consumption	Approx. 21 watt	Approx. 19 watt
Dimensions (W*H*D) mm	357 x 283 x 64	401.5 x 251x 60.3
Weight	3.2 kg	3.4kg
Operating temperature	0° to 40° C	

Subject to technical changes without prior notice. Error excepted.

Monitor model	L172AVL	L185AVL	L192AVL
System	PAL / NTSC		
LCD panel	17"	18.5"	19"
Visible area (mm)	338 x 270	409.8 x 230.4	376 x 301
Picture format	4:3	16:9	4:3
Max. resolution	1280 x 1024	1366 x 768	1280 x 1024
Pixel dot pitch (mm)	0.264 x 0.264	0.3 x 0.3	0.098 x 0.249
Colours	16.7M	16.7M	16.7M
Brightness	250 cd/m <sup>2</sup>   400 cd/m <sup>2</sup>	250 cd/m <sup>2</sup> [LED]	250 cd/m <sup>2</sup> [LED]
Contrast	1000 :1	1000:1	1000:1
Response time	1.2/3.8 ms	3.6/1.4 ms	1.3/3.7 ms
View angle (U/D/L/R)	80/80/80/80	80/80/85/85	80/80/85/85
Video input/output	2 x / 2 x Composite (BNC)		
S-Video input	1 x 4 Pin Mini Dim		
Full HD input	1x (A Type)		
Audio input/output	2 x / 2 x (RCA)		
PC input	1 x VGA input (D-Sub 15 pin) 1x DVI-D input 1x Audio input		
PC input	1 x VGA input (D-Sub 15 pin)		
Speaker	1 x built-in speaker (2 watt)		
3D Comb Filter	Yes		
3D De-Interlace function	Yes		
Picture-in-Picture (PIP)	Yes (video/PC)		
OSD setting	Yes		
Power input	AC 100-240V 50/60Hz, Adapter DC 12V/5A		
Power consumption	Approx. 30 watt	Approx. 21 watt	Approx. 25 watt
Dimensions (W*H*D) mm	391 x 352 x 69	464.4 x 285 x 63.2	430x 356 x 66.7
Weight	3.9kg	4.2 kg	5.5kg
Operating temperature	0° to 40° C		

Subject to technical changes without prior notice. Error excepted.

Monitor model	L215HDL	L220AVL
System	PAL / NTSC	
LCD panel	21.5"	22"
Visible area (mm)	476.6 x 268.1	473.7 x 296.1
Picture format	16:9	16:9
Max. resolution	1920 x 1080	1680 x 1050
Pixel dot pitch (mm)	0.248 x 0.248	0.282 x 0.282
Colours	16.7M	16.7M
Brightness	250 cd/m <sup>2</sup> [LED]	250 cd/m <sup>2</sup> [LED]
Contrast	1000 :1	1000:1
Response time(Tr/Tf)	1.3/3.7 ms	3.6/1.4 ms
View angle (U/D/L/R)	80/80/85/85	80/80/85/85
Video input/output	2x / 2x Composite (BNC)	
S-Video input	1 x 4 Pin Mini Dim	
Full HD input	1 x Full HD (A Type)	
Audio input/output	2 x / 2 x (RCA)	
PC input	1 x VGA input (D-Sub 15 pin) 1 x DVI-D input 1 x Audio input	
Speaker	1 x built-in speaker (2 watt)	
3D Comb Filter	Yes	
3D De-Interlace function	Yes	
Picture-in-Picture (PIP)	Yes (video/PC)	
OSD setting	Yes	
Power input	AC 100-240V 50/60Hz, Adapter DC 12V/5A	
Power consumption	Approx. 22 watt	Approx. 23 watt
Dimensions (WxHxD) mm	532.3 x 323.3x 65	525 x 345x 65
Weight	5.7kg	6.0kg
Operating temperature	0° to 40° C	

Subject to technical changes without prior notice. Error excepted.

Monitor model	L240HDL	L270HDL
System	PAL / NTSC	
LCD panel	24"	27"
Visible area (mm)	531.3 x 298.8	597.6 x 336.15
Picture format	16:9	16:9
Max. resolution	1920 x 1080	1920 x 1080
Pixel dot pitch (mm)	0.276.7 x 0.276 .7	0.31125 x 0.31125
Colours	16.7M	16.7M
Brightness	250 cd/m <sup>2</sup> [LED]	300 cd/m <sup>2</sup> [LED]
Contrast	1000:1	5000:1
Response time(Tr/Tf)	3.5/1.5 ms	7/5 ms
View angle (U/D/L/R)	80/80/85/85	89/89/89/89
Video input/output	2x / 2x Composite (BNC)	
S-Video input	1 x 4 Pin Mini Dim	
Full HD input	1 x Full HD (A Type)	
Audio input/output	2 x / 2x (RCA)	
PC input	1x VGA input (D-Sub 15 pin) 1 x DVI-D input 1 x Audio input	
Speaker	1 x built-in speaker (2 watt)	
3D Comb Filter	Yes	
3D De-Interlace function	Yes	
Picture-in-Picture (PIP)	Yes (video/PC)	
OSD setting	Yes	
Power input	AC 100-240V 50/60Hz, Adapter DC 12V/5A	
Power consumption	Approx. 24watt	Approx. 28.5watt
Dimensions (WxHxD) mm	575.9 x 347.8 x 56.7	658 x 396.6 x 60.5
Weight	5.7kg	7kg
Operating temperature	0° to 40° C	

Subject to technical changes without prior notice. Error excepted.

Monitor model	L320HDL	L420HDL
System	PAL / NTSC	
LCD panel	31.5"	42"
Visible area (mm)	698.4 x 392.8	930.2x 523.2
Picture format	16: 9	16:9
Max. resolution	1920 x 1080	1920x1080
Pixel dot pitch (mm)	0.36375x 0.37375	0.4845x0.4845
Colours	16.7M	16.7M
Brightness	450 cd/m <sup>2</sup> [CCFL] 350 cd/m <sup>2</sup> [LED]	350 cd/m <sup>2</sup> [LED]
Contrast	5000:1 3000 :1	3000:1
Response time (G to G)	6.5ms	6.5ms
View angle (U/D/L/R)	89/89/89/89	89/89/89/89
Video input/output	2x / 2x Composite (BNC)	
S-Video input/output	1 x 1 x 4 Pin Mini Dim	
Full HD input	1 x Full HD (A Type)	
Audio R/L input/output	2x / 2x (RCA)	
PC input	1 x VGA input (D-Sub 15 pin) 1x DVI-D input 1x Audio input	
Speaker	2 x built-in speaker	
3D Comb Filter	Yes	
3D De-Interlace function	Yes	
Picture-in-Picture (PIP)	Yes (video/PC)	
OSD setting	Yes	
Power input	AC 100-240V 50/60Hz	
Power consumption	Approx. 57 watt	Approx. 75 watt
Dimensions (WxHxD) mm	761.6x 455.2 x 75	994.6x 587.2x 81
Weight	13kg	23kg
Operating temperature	0° to 40° C	

Subject to technical changes without prior notice. Error excepted.

## **Appendixes**

### **Troubleshooting**

The tables provided below include some problems that the user may encounter while using the display and the corresponding solutions. Please refer to the contents of this section prior to contacting service personnel.

Problem	Possible Causes	Solutions
No picture	<ol style="list-style-type: none"><li>1. Is the power cable connected to the unit?</li><li>2. Is the unit turned on?</li><li>3. Is the signal cable connected to the unit?</li><li>4. Is the unit in power saving mode?</li></ol>	<ol style="list-style-type: none"><li>1. Make sure the power cable has been properly connected to the unit.</li><li>2. Turn on the unit.</li><li>3. Make sure the signal cable has been properly connected to the unit.</li><li>4. Press any key on computer keyboard.</li></ol>
Strange colour	<ol style="list-style-type: none"><li>1. Is the signal cable connected to the unit?</li></ol>	<ol style="list-style-type: none"><li>1. Make sure the signal cable has been properly connected to the unit.</li></ol>
Picture distortion	<ol style="list-style-type: none"><li>1. Is the signal cable connected to the unit?</li><li>2. Is the video input signal within the unit's specified frequency range?</li></ol>	<ol style="list-style-type: none"><li>1. Make sure the signal cable has been properly connected to the unit.</li><li>2. Make sure the input signal is within the unit's specified frequency range.</li></ol>
Picture is too dim	<ol style="list-style-type: none"><li>1. Have the unit's brightness and contrast settings been set to the lowest level?</li></ol>	<ol style="list-style-type: none"><li>1. Adjust brightness and contrast</li></ol>
Only sound but no picture	<ol style="list-style-type: none"><li>1. Is the connection of the input signal correct?</li></ol>	<ol style="list-style-type: none"><li>1. Check connection of input signal.</li><li>2. Make sure the signal cable has been properly connected.</li></ol>
Only picture but no sound	<ol style="list-style-type: none"><li>1. Is the signal cable connected to the unit?</li><li>2. Has the volume been set to the min level?</li><li>3. Is the audio cable connected to the unit?</li></ol>	<ol style="list-style-type: none"><li>1. Make sure the signal cable has been properly connected to the unit.</li><li>2. Adjust the volume to an appropriate setting.</li><li>3. Make sure the audio cable has been properly connected to the unit.</li></ol>

Please contact the customer service centre of your local dealer if you have any questions regarding the unit after reading the information provided above.