

AUTODOME inteox 7000i - 2MP OC



- ▶ AI-based traffic detection for traffic monitoring (no camera calibration required)
- ▶ Open platform that allows third-party apps from the Application store from Security & Safety Things
- ▶ Starlight technology with excellent low-light performance and High dynamic range of 120 dB to see detail in difficult light conditions
- ▶ Flexible streaming capabilities powering three independent streams
- ▶ Built-in Intelligent Video Analytics alert operators in case of unusual scene activity

The AUTODOME inteox 7000i camera is an advanced, 30x PTZ surveillance camera based on an open operating system, driven by OSSA, from Security and Safety Things. With starlight imaging technology for excellent low-light sensitivity, the most robust Video Analytics on the market, and video streaming, the camera delivers unmatched picture quality. Even under the most challenging light conditions, the camera delivers high-definition (HD) 1080p video. Easy to install, the camera is available in either a field-proven, outdoor pendant housing or an indoor, in-ceiling housing.

Intelligent open, flexible, and extendable camera platform

The camera has a powerful, embedded processor with dedicated hardware to support advanced machine learning and neural-network-based Video Analytics. All cameras with this platform have high image quality, built-in Video Analytics, intelligent bitrate management, and the highest levels of data security. The platform also gives you the flexibility to customize your camera to your specific requirements. The camera platform integrates with the cloud infrastructure of Security and Safety Things for app management across devices. Also, Bosch offers advanced device management and services through

the Bosch Remote Portal (<https://remote.boschsecurity.com/>). From the Bosch Remote Portal you can (remotely):

- Complete initial configuration of your online and connected Bosch devices.
- Update firmware for single or multiple devices.
- Manage certificates through Configuration Manager or the web interface of your camera.
- Monitor the health of and receive alerts for your connected Bosch devices.
- Connect your Bosch devices to the Security and Safety Things portal for app management.

AI-based traffic detection for traffic monitoring

The camera includes an AI-based traffic detector to detect and track cars in front of traffic lights, on intersections, roads, highways, and in tunnels. Even in dense traffic such as vehicles stopped at traffic lights and in traffic jams, the AI-based traffic detector reliably separates the different cars for accurate counting results.

Functions

Exceptional low-light performance

The latest sensor technology combined with the sophisticated noise suppression results in an exceptional sensitivity in color. The low-light

performance is so good that the camera continues to provide excellent color performance even with a minimum of ambient light.

High dynamic range

The dynamic range of the camera is outstanding and is obvious in real-world performance comparisons. In extended dynamic range mode, the camera uses an electronic shutter to capture four images with different exposure time and reproduce a high-contrast frame. The result is that you can view details in both the bright areas (highlights) and the dark areas (shadows) of a scene at the same time. You can easily distinguish objects and features (for example, faces) with bright backlight.

H.265 high-efficiency video encoding

The camera is designed on the most efficient and powerful H.264 and H.265/HEVC encoding platform. The camera is capable of delivering high-quality and high-resolution video with very low network load. With a doubling of encoding efficiency, H.265 is the new compression standard of choice for IP video surveillance systems.

More flexibility in streaming capabilities

The camera has three independent encoder streams. Users can configure each stream individually to change the video resolution and the frame rate. Users have two options:

1. Let the camera deliver what is possible based on its encoding performance across the streams equally.
2. Select one of the three streams to be prioritized, for example, to guarantee “quality of service” for the recording stream.

Users can select the coding standard (H.264/H.265) for each stream.

Each stream also has its own set of 8 encoder profiles that users can configure.

Intelligent Video Analytics on the edge

This intelligence-at-the-edge concept allows a decision on which videos are captured based on video content analysis. By only selecting alarm video for streaming or recording, less bandwidth and storage is used. Alarm conditions can be signaled by a relay output on the unit or an alarm connection, to stream video to a decoder or video management system. Alarms can also be transmitted to a video management system to start extended alarm scenarios.

As well as creating alarms, Intelligent Video Analytics produces metadata that describes the content of the analyzed scene. This metadata is sent over the network—and may also be recorded—together with the video stream.

With a future-proof design, the camera can tackle new use cases by delivering more reliable detections and thus more insights on what is happening in a scene. Based on the open platform principle, these capabilities are leveraged by

Intelligent Video Analytics by Bosch as well as by third-party apps from the Application store from by Bosch as well as by third-party apps from the Application store from Security and Safety Things.

Video Analytics while camera is moving

Outside of pre-positions and even while the PTZ camera is moving, whether on guard tours or manually, the Intelligent Video Analytics application can detect and start alarms when objects are in alarm fields. These alarm fields are defined once across all PTZ camera views. The camera can automatically trigger an alarm if any part of a field within the camera's view becomes active while on a guard tour sweeping across the monitored areas.

Auto Exposure (AE) region and Focus region

With the Auto Exposure (AE) function, the camera computes the lighting condition of the entire scene. Then the camera determines the optimum level of iris, gain, and shutter speed.

In AE region mode, users can designate a specified area of the scene, based on pre-positions. The camera computes the lighting condition of the specified area. Then the camera determines the optimum level of iris, gain, and shutter speed to get an image.

Focus region mode, unlike normal auto focus mode, allows users to focus on a specified area of the scene. Users have the ability to customize these modes, if necessary, for the specific requirements of the site.

Image Stabilization

Cameras on unstable mounts can move sufficiently to change the field of view. The higher the zoom value, the larger the change of the field of view. This change can make images unusable.

The camera has an Image stabilization algorithm that lets the camera sense continuous vibration. If it detects vibration, the camera corrects the shaky video in the vertical axis and the horizontal axis. The result is excellent image clarity and a stable field of view on the monitor. The Image stabilization function is important to eliminate movement that unstable camera mounts cause.

DORI coverage

DORI (Detect, Observe, Recognize, Identify) is a standard system (EN-62676-4) for defining the ability of a person viewing the video to distinguish persons or objects within a covered area. The maximum distance at which a camera/lens combination can meet these criteria is shown below:

The nylon bubble material is required to meet the IK10 shock rating. The optical characteristics of nylon compared to the standard acrylic bubble affect the resolution and sharpness of the video image.

For the camera to give the best image that fits your application, consider the important limitations in the table that follows:

DORI	Distance to object (30x optical zoom)
------	---------------------------------------

	Standard bubble (acrylic)		IK10 bubble (nylon)	
	WIDE 1X	TELE 30X	TELE 30 X	Scene width
Detection 25 px/m (8 px/ft)	61 m (200 ft)	1913 m (6276 ft)	1200 m (3937 ft)	77 m (253 ft)
Observation 63 px/m (19 px/ft)	24 m (79 ft)	765 m (2510 ft)	600 m (1969 ft)	31 m (102 ft)
Recognition 125 px/m (38 px/ft)	12 m (39 ft)	383 m (1257 ft)	300 m (984 ft)	15 m (49 ft)
Identification 250 px/m (76 px/ft)	6 m (20 ft)	191 m (627 ft)	191 m (627 ft)	8 m (26 ft)

Simple set-up

The camera has a very intuitive user interface that allows fast and easy configuration. Configurable scene modes are provided with the best settings for a variety of applications.

- **Standard**

This mode is optimized for most standard scenes both indoor and outdoor.

- **Color Only (Traffic)**

In this mode, the camera does not switch to monochrome mode at low light levels. The mode is optimized to minimize motion artifacts and to capture the color of vehicles/pedestrians and traffic lights, even at night, for scenarios such as city surveillance and traffic monitoring.

- **Indoor**

This mode is ideal for indoor applications where lighting is constant and does not change. Auto white balance will be mainly focused on low color temperature 3200K.

- **Sensitivity boost**

This mode provides maximum sensitivity in low light scenes by using longer exposure times, resulting in bright images even in extreme low light.

- **Fast movement**

This mode is used for monitoring fast moving objects like cars in traffic scenes. Motion artifacts are minimized and the image is optimized for a sharp and detailed picture in color and monochrome.

- **Vibrant**

This mode provides a more vivid image with increased contrast, sharpness, and saturation.

Sophisticated alarm responses

The camera supports advanced alarm control that uses sophisticated rules-based logic to determine how to manage alarms. In its most basic form, a “rule” could define which input(s) should activate which

output(s). In a more complex form, inputs and outputs can be combined with pre-defined or user-specified commands to perform advanced camera functions.

Pre-positions and tours

The camera supports 256 pre-positions and two styles of Guard Tours: Pre-position and Record/Playback. The Pre-position tour has capability for up to 256 pre-positions with a configurable dwell time between pre-positions and can be customized as to the order and the frequency that each Pre-position is visited. The camera also provides support for two (2) recorded tours, which have a total duration of 15 minutes of movements. These are recorded macros of an operator’s movements, including pan, tilt, and zoom activities, and can be played back in a continuous manner.

Snap to zoom

Drawing a box in the image will trigger the camera to zoom to the correct position.

PTZ drive and mechanism

The camera offers a reliable drive platform, designed for continuous tours for at least three years. It provides an unlimited three-year warranty. Its design provides optimum smoothness in motion when used at low speeds or with a joystick.

Pan and tilt preset repeatability are accurate to within ± 0.1 degrees to ensure that the correct scene is captured every time. The camera delivers variable pan/tilt speeds from a crawl speed of only 0.1 degrees per second to a full 400 degrees per second. The camera is capable of pan speeds of 400 degrees per second and tilt speeds of 300 degrees per second between pre-positions. The camera provides a tilt angle 18 degrees above the horizon, and a pan range of up to 360 degrees continuous rotation.

Data security

Special measures are necessary to ensure the highest level of security for device access and data transport. On initial setup, the camera is only accessible over secure channels. A three-level password protection with security recommendations lets users customize device access. Unsecure ports are disabled. Firmware updates are only possible with Bosch-signed firmware files. The Embedded Login Firewall improves robustness against Denial of Service (DoS) attacks. The software sealing functionality can detect changes in a configuration. HTTPS or other secure protocols prevent access to the web browser and the viewing client. With the feature of secure and verified boot, you can trust all executed code in the device. TPM functionality is provided by “Secure Element” (dedicated AES/DES/PKI crypto co-processor) that:

- Is independently certified with Assurance Level (EAL) 6+ based on Common Criteria for Information Technology Security Evaluation [out of 7 levels according to ISO/IEC 15408]

- Has cryptography with a maximum of 4096 bit RSA keys for TLS (maximum version 1.3) and device identity (Future-proof until 2031 and beyond) [according to NIST Special Publication 800-57, part 1, page 56]

The advanced certificate handling offers:

- Self-signed, unique certificates automatically created when required
- Client and server certificates for authentication
- Client certificates for proof of authenticity
- Certificates with encrypted private keys

Only trusted and authenticated third-party apps can be uploaded. A safe sandbox environment enables the secure execution of trusted third-party software. There is full transparency on individual app requirements to access system resources (listed in the Application store from Security and Safety Things).

Power options

The camera can be powered by one of the devices in the list that follows:

- a 30 W (IEEE 802.3at) midspan
- a 30 W network switch
- a 60 W midspan

In a PoE configuration, a single (Cat5e/Cat6e) cable connection provides power while simultaneously supporting data and video transmission. For maximum reliability, the camera can operate in a redundant configuration, with both a 24 VAC power source and a midspan or a switch connected simultaneously. If either power source fails, the camera switches automatically to the other power source. The camera can also accept a standard 24 VAC power source if a PoE network interface will not be used.

For pendant models used in outdoor applications that require heaters, a 60 W Bosch midspan or a 60 W switch is required to power both the camera and its internal heaters.

For in-ceiling or indoor pendant applications that do not require heater power, a standard 30 W (IEEE 802.3at) midspan or a 30 W switch can be used to power the camera.

System integration and ONVIF conformance

The camera conforms to the specifications for ONVIF Profile S and ONVIF Profile G. (ONVIF is the acronym for Open Network Video Interface Forum.) For H.265 configuration, the camera also supports Media Service 2, which is part of ONVIF Profile T. Compliance with these standards guarantees interoperability between network video products, regardless of manufacturer. Third-party integrators can easily access the internal feature set of the camera for integration into large projects. For more information, see the Bosch Integration Partner Program (IPP) website (ipp.boschsecurity.com).

Cameras with this platform are intended to be backwards compatible with existing VMS integrations. Compatibility of the app feature set that is available in the Application store is the responsibility of the app developer and of Security and Safety Things.

Design for challenging environments

Pendant housings are rated to provide IP66 protection and offer an operating temperature range down to -40 °C (-40 °F). The pendant model comes fully assembled with a sunshield which can be easily removed for use in indoor applications. In addition, both pendant and in-ceiling camera models have a high-resolution acrylic bubble for enhanced image clarity.

Ease of installation and servicing

The camera has been designed for quick and easy installation, a key feature from Bosch IP video products. All housings feature recessed screws and latches for increased tamper resistance.

Bosch offers a full complement of hardware and accessories (sold separately) for wall, corner, mast, roof, and pipe mount for indoor and outdoor environments, which allow the camera to be adapted easily to individual site requirements.

Remotely upgrade the camera whenever new firmware becomes available. This ensures up-to-date products, thus protecting investment with little effort.

Camera Diagnostics

The camera has several built-in sensors / advanced diagnostics that display warnings on the camera's OSD about the health of the camera. The diagnostics log records the events such as:

- Low voltage - a drop in incoming power below the level where the camera becomes non-functional
- High temperature - the internal temperature exceeds specifications
- Low temperature - the internal temperature exceeds minimum levels
- High humidity - the internal humidity exceeds 70%
- Total hours of camera operation

Certain events also appear on the camera's OSD.

These diagnostic records are available for the installation or service technician to review.

Certifications and approvals

For a full list of all related certifications/standards, refer to the Product Tests Report, available on the online catalog, on the Documents tab of the product page for your device. If the document is unavailable on the product page, contact your sales representative.

Electromagnetic compatibility (EMC)	FCC Part 15, ICES-003 EN 55024:2010 + A1:2015 EN 55032:2015/AC:2016
Product Safety	Complies with UL, CE, CSA, EN, and IEC standards including: UL 62368-1

EN 62368-1
 EN 60950-1
 CAN/CSA-C22.2 No. 62368-1-14
 IEC 62368-1 Ed.2
 IEC 60950-1 Ed.2
 IEC 60950-22 Ed.2

Marks UL, CE, WEEE, RCM, EAC, VCCI, FCC, RoHS

Region	Regulatory compliance/quality marks	
Europe	CE	Declaration of Conformity (DoC) - AUTODOME IP starlight 7000i

Installation/configuration notes

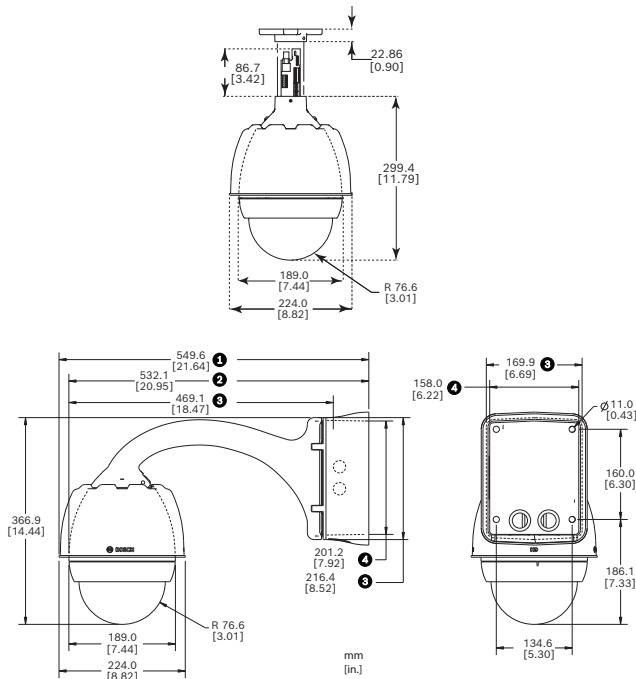

Fig. 1: Dimensions, AUTODOME7000 pipe mount, pendant mount

- 1 Power supply box and sunshield
- 2 Sunshield removed
- 3 Mounting plate
- 4 Power supply box

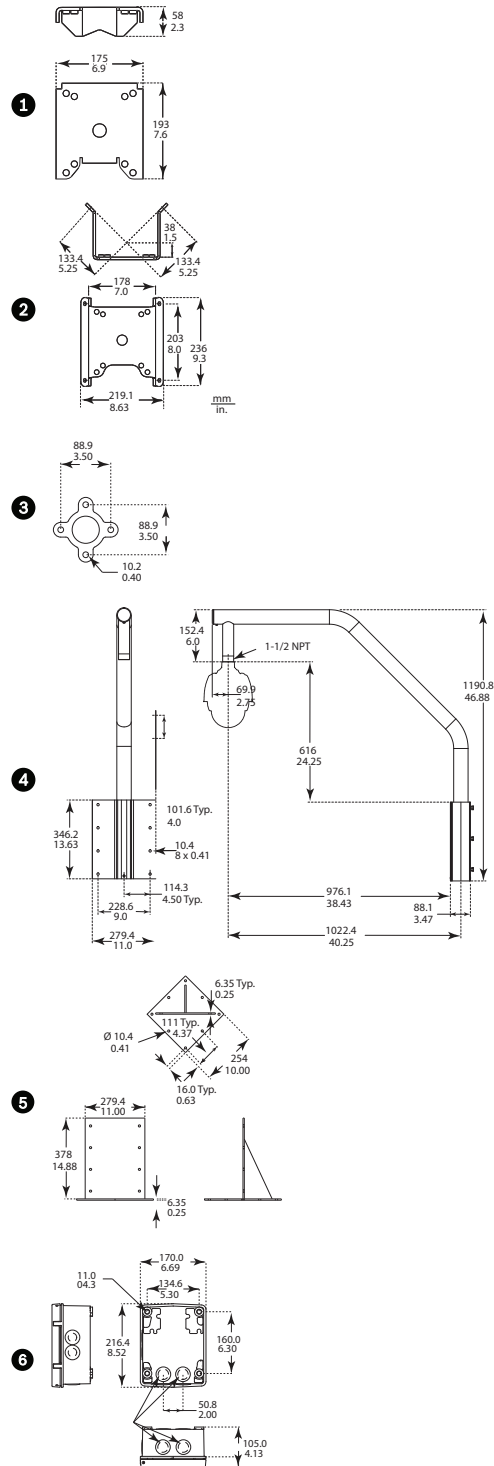

Fig. 2: AUTODOME 7000 series Optional Mounts

- 1 Pole (Mast) Mount
- 2 Corner Mount
- 3 Pipe Mount
- 4 Roof Mount
- 5 Roof Mount Adapter
- 6 Power Supply for Pipe and Roof Mounts

Technical specifications

Imager	1/2.8 in. CMOS sensor
Effective Picture Elements (Pixels)	1944 x 1212 (2.35 MP)
Lens	30x motorized Zoom 4.3 mm to 129 mm F1.6 to F4.7
Field of View (FOV)	2.3° to 64.7°
Focus	Automatic with manual override
Iris	Automatic with manual override
Digital Zoom	12x
Day/Night switch	Automatic IR cut filter

Video performance - Sensitivity

(3100K, reflectivity 89%, 1/30, F1.6, 30 IRE)

Color	0.0077 lx
Monochrome	0.0008 lx

Video performance - Dynamic range

High dynamic range	120 dB WDR
Measured according to IEC 62676 Part 5	100 dB WDR

Gain control	AGC, Fixed, Region per pre-position
Aperture Correction	Horizontal and vertical
Electronic Shutter Speed (AES)	1/1 sec to 1/30,000 sec (22 steps)
Signal-to-Noise Ratio (SNR)	>55 dB
Backlight compensation (BLC)	On / Off / Intelligent Auto Exposure (IAE)
White balance	2000 K to 10,000 K ATW, AWB Hold, Extended ATW, Manual, Sodium Lamp Auto, Sodium Lamp, indoor, outdoor
Day/Night	Monochrome, Color, Auto
Defog mode feature	Improves visibility when viewing foggy or other low-contrast scenes.
Noise Reduction	Intelligent Dynamic Noise Reduction

Modes for viewing the video area of pre-position settings	Automatic exposure, either full-screen or defined to a specific area Focus
---	---

Sectors	4, 6, 8, 9, 12, or 16 user-selectable, independent Sectors, each with 20 characters per Title
Privacy Masks	32 individually configurable Privacy Masks; maximum 8 per Pre-position; programmable with 3, 4 or 5 corners; select your own color from the color palette. With the "Auto" option, the camera selects the most prevalent of the three colors in the background scene as the pattern color. With the "Mosaic" option, the movements behind a Privacy Mask will remain visible.
Virtual Masks	24 individually configurable Virtual Masks to hide parts of the scene (background motion such as moving trees, pulsating lights, busy roads, etc.)
Pre-positions	256 Pre-positions, each with 20 characters per Title
Guard Tours	Custom Recorded Tours - two (2), total duration 30 minutes: Pre-position tour - one (1), consisting of up to 256 scenes consecutively, and one (1) customized with up to 256 user-defined scenes
Supported Languages	English, Czech, Dutch, French, German, Italian, Polish, Portuguese, Russian, Spanish, Japanese, Chinese
Alarm control	Rules-based logic supports basic and complex pre-defined user-specified commands In its most basic form, a "rule" could define which input(s) should activate which output(s).
Camera status monitoring	Integrated sensors monitor operational status such as internal temperature, humidity level, incoming voltage level, vibration, and shock events.
Diagnostics	Various status conditions are tracked in the internal diagnostic log. Critical fault conditions will also be displayed on screen.

Firmware

Common Product Platform	CPP13
-------------------------	-------

Video content analysis

Analysis type	Intelligent Video Analytics
Configurations	Off / Global VCA / Profiles 1 - 16
Calibration	Automatic self-calibrating when height is set

Alarm rules (combinable)	Any object, Object in field, Crossing line, Entering field, Leaving field, Loitering, Following route, Idle object, Removed object, Counter, Occupancy, Crowd detection, Condition change, Similarity search, Tampering
Object filters	Duration, Size, Aspect ratio v/h, Speed, Direction, Object classes (Upright persons, Bikes, Cars, Trucks), Color
AI detectors	Traffic monitoring
Network	
Standard/Video compression	H.265, H.264 (ISO/IEC 14496), M-JPEG, JPEG
Streaming	3 fully configurable streams, with the option to activate or deactivate VCA overlays on each stream
Protocols	IPv4, IPv6, UDP, TCP, HTTP, HTTPS, RTP/RTCP, IGMP V2/V3, ICMP, ICMPv6, RTSP, FTP, ARP, DHCP, APIPA (Auto-IP, link local address), NTP (SNTP), DNS, DNSv6, DDNS (DynDNS.org, selfHOST.de, noip.com), SMTP, iSCSI, UPnP (SSDP), DiffServ (QoS), LLDP, SOAP, Dropbox™, CHAP, digest authentication
Ethernet	100BASE-TX, auto-sensing, full duplex/auto negotiation, Auto-MDI-X
Encryption	TLS1.0/1.2, AES128, AES256
Ethernet connector	RJ45
GOP structure	IP, IBP, IBBP
Overall IP Delay	30 fps: 233 ms (typical)
Interoperability	ONVIF Profile S, ONVIF Profile G, ONVIF Profile T
Resolution (H x V)	Pixels
1080p HD	1920 x 1080
720p HD	1280 x 720
432p SD	768 x 432
288p SD	512 x 288

The table that follows shows the average typical optimized bitrate, in kbits/s, for different frame rates: The average is for the highest resolution of the camera.

FPS	H.264	H.265
30	2470	2060
25	2410	1810
15	1690	1260
8	1090	820
4	670	500
2	420	310
1	260	190

Actual bitrate may vary depending on the scene complexities and encoding configurations.

Local Storage

Memory Card Slot	User-supplied full SD card (maximum 2 TB) Note: For this camera, Bosch does not recommend the use of microSD cards or of microSD to SD adapters.
Recording	Continuous recording of video and audio, alarm/ events/schedule recording

Mechanical

Pan Range	360° cont.
Tilt Angle	18° above horizon
Pre-position Speed	Pan: 400°/s Tilt: 300°/s
Pan/Tilt Modes	
• Turbo Mode (Manual Control)	Pan: 0.1°/s - 400°/s Tilt: 0.1°/s - 300°/s
• Normal Mode	0.1°/s-120°/s
Pre-position Accuracy	± 0.1° typ.

Electrical

Input voltage	24 VAC 60 W (using the midspan accessory NPD-6001B, required to power the heater) 30 W (IEEE 802.3at, class 4 standard, when used without powering the heater)
Power Consumption (typical), with heaters	51.0 W / 54.0 VA

Power Consumption (typical)	19.2 W / 33.6 VA (heaters off / without heater connected in 24 V power supply box)
Current consumption, 24 VAC	~2.25A
Current consumption, 60 W	~0.91A
Redundant configuration	Connect a 30 W or a 60 W midspan ¹ and a separate 24 VAC power source. If either power source fails, the camera switches automatically to the other power source.
Surge suppression	Built-in surge suppression for power, data, and network interfaces (Refer to the A&E Specifications for details.)

User Connections

Power, Network	RJ45 100Base-T
Power, Camera	24VAC, 50/60Hz
Alarm Inputs (7)	2 supervised, 5 non-supervised
Alarm Outputs (4)	1 dry contact relay, 3 open collector/transistor outputs Programmable for "normally open" or "normally closed" 32 VDC @ 150 mA maximum
Audio	1 x mono line in, 1 x mono line out Signal line in: 20 kOhm typical, 0.707 Vrms Signal line out: 0.707 Vrms at 16 Ohm, typical

Communications / Software Control

Camera Setup/Control	Via web browser [Refer to the Release Letter of your camera's firmware for specific requirements.], Bosch Configuration Manager, Bosch Video Management System (BVMS), Video Security Client (VSC), Project Assistant, or support for third party software
Software Update	Network firmware upload

Fiber Optic Kit

VG4-SFPSCKT

Description	Fiber Optic Ethernet Media Converter kit ² . Requires a small form-factor pluggable (SFP) module (sold separately).
Data Interface	Ethernet

Data Rate	100 Mbps IEEE 802.3 Compliant Full Duplex or Half Duplex Electrical Port Full Duplex Optical Port
Compatible Receiver	CNFE2MC
Installation	Installed inside a VG4-A-PA0, VG4-A-PA1, VG4-A-PA2, VG4-A-PSU1, or a VG4-A-PSU2 power supply box with supplied mounting hardware

². Kit available separately and must be installed inside the AUTODOME power supply box.

SFP Modules

Description	Interchangeable modules available for use with MMF or SMF optical fiber.
Data Interface	Ethernet
Data Rate	100 Mbps IEEE 802.3 Compliant
Weight (all SFP modules)	0.23 kg (0.05 lb)
Dimensions (LxWxH)	SFP-2, SFP-3: 55.5 x 13.5 x 8.5 mm (2.2 x 0.5 x 0.3 in.) SFP-25, SFP-26: 63.8 x 13.5 x 8.5 mm (2.5 x 0.5 x 0.3 in.)

	Type	Connector	Wavelength (transmit / receive)	Max. Distance
SFP-2	MMF	Duplex LC	1310 nm / 1310 nm	2 km (1.2 miles)
SFP-3	SMF	Duplex LC	1310 nm / 1310 nm	20 km (12.4 miles)
SFP-25	MMF	Single SC	1310 nm / 1550 nm	2 km (1.2 miles)
SFP-26	MMF	Single SC	1550 nm / 1310 nm	2 km (1.2 miles)

Fiber Compatibility

Optical Fiber Compatibility, MMF	50/125 µm MMF. For 50/125 µm fiber, subtract 4 dB from the specified optical budget value. Must meet or exceed fiber standard ITU-T G.651.
Optical Fiber Compatibility, SMF	8-10/125 µm SMF. Must meet or exceed fiber standard ITU-T G.652.
Optical Distance Specifications	Specified transmission distances are limited to the optical loss of the fiber and any additional loss introduced by connectors, splices, and patch

panels. The modules are designed to operate over the entire optical loss budget range, so they do not require a minimum loss in order to operate.

Environmental

Ingress Protection Rating/Standard	IP66, NEMA 4X ³
Operating temperature (with heater wired)	-40 to +55 °C (-40 to +131 °F) -10 to +55 °C (+14 to +131 °F) (without heater wired) Maximum temperature: 74 °C (165 °F) in accordance with NEMA TS 2-2003 (R2008)
Storage temperature	-40 to +60 °C (-40 to +140 °F)
Operating Humidity	0% to 100% RH, condensing
Vibration	IEC 60068-2-6 NEMA TS2 Section 2.2.8
Shock	IEC 60068-2-27 NEMA TS2 Section 2.2.9
Power Service Transients	NEMA TS2 Section 2.2.7.2
Power Interruption	NEMA TS2 Section 2.2.10
Salt Mist Spray (Corrosion Test)	IEC 60068-2-52
External Mechanical Impact	IEC 60068-2-75: IK10 (only models ending in "-K")
	3. NEMA 4X for: -Access to Hazardous parts -Ingress of solid foreign objects (falling dirt, circulating dust, settling dust) -Ingress of water (dripping and light splashing, hose down and splashing)

-Corrosive agents

Meets requirements for NEMA 4X certification (only models ending in "-K").

Meets requirements for NEMA 4X, except impact test (only pendant models, non-IK10).

Construction

Dimensions	224 mm (8.8 in.) x 299.4 mm (11.8 in.)
Weight	3.2 kg (7 lb)
Bubble Size	153.1 mm diameter (6.03 in.)

Construction Material , Housing	Cast aluminum
Construction Material , Bubble	Acrylic
Standard Color	White (RAL 9003)
Standard Finish	Powder coated, sand finish

Mounts/Accessories

In-ceiling bubbles

Clear HD high-resolution acrylic	VGA-BUBHD-CCLA
Tinted HD high-resolution acrylic (Included with in-ceiling camera models.)	VGA-BUBHD-CTIA

Pendant bubbles

Clear high-resolution acrylic (Included with pendant camera models.)	VGA-BUBBLE-PCLA
Tinted high-resolution acrylic	VGA-BUBBLE-PTIA
Clear rugged IK10-rated nylon*	VGA-BUBBLE-IK10

Mounts

Pendant Arm Mounts

Wall Arms	VG4-A-PA0 (no transformer) VG4-A-PA1 (120 VAC transformer) VG4-A-PA2 (230 VAC transformer)
Pendant Arm with Wiring	VG4-PEND-ARM
Mounting plate for VG4-PEND-ARM	VG4-PEND-WPLATE

Optional Mounting Plates for Arm Mounts

Corner Mounting Plate	VG4-A-9542
Pole Mounting Plate	VG4-A-9541

Pendant Pipe Mounts

Pipe Mount Kit	VG4-A-9543
----------------	------------

Pendant Roof Mounts

Roof (Parapet) Mount (VG4-A-9543 Pipe Mount Kit required. Available separately.)	VGA-ROOF-MOUNT (with 1.5-inch NPT tapered male threads)
---	---

Optional Mounting Plates for Roof Mounts

Flat Roof Adapter for Parapet Mount	LTC 9230/01
In-ceiling Support Kits	VGA-IC-SP (Bracket for suspended or drop ceilings)

Ordering information

NDP-7602-Z30-OC PTZ 2MP 30x starlight clear pendant OC

PTZ dome camera, 2MP, 30x, starlight imaging, H.265, IVA, open camera platform
open camera platform
AI-based traffic detection for traffic monitoring
Order number **NDP-7602-Z30-OC | F.01U.382.880**
F.01U.386.562

Accessories

NPD-6001B Midspan, 60W, single port, AC in
60 W indoor midspan for cameras without illuminators
Order number **NPD-6001B | F.01U.347.358**
F.01U.392.458

NPD-9501-E Midspan 95W 1 port outdoor
95 W outdoor midspan for AUTODOME 7000 and MIC IP cameras with or without illuminators
Order number **NPD-9501-E | F.01U.365.279**

NDA-9501-PMA Pole mount adapter for NPD-9501-E
Pole mount adapter for outdoor midspan
Order number **NDA-9501-PMA | F.01U.374.407**

VG4-A-PSU0 Power supply, 24VAC
Power supply, 24 VAC input, for a PTZ camera in the AUTODOME Series. White, aluminum enclosure with cover, rated IP66 and IK 08. 100 W output.
Order number **VG4-A-PSU0 | F.01U.261.376**

VG4-A-PSU1 PSU, 120VAC, for AUTODOME, MIC7000
Power supply for AUTODOME 7000, MIC IP cameras without illuminators.
120VAC in, 24VAC out
Order number **VG4-A-PSU1 | F.01U.261.377**
F.01U.009.667 F.01U.081.593

VG4-A-PSU2 Power supply, 230VAC, AUTODOME, MIC7000
Power supply for AUTODOME 7000, MIC IP cameras without illuminators.
230VAC in, 24VAC out
Order number **VG4-A-PSU2 | F.01U.009.668**
F.01U.096.639 F.01U.097.433 F.01U.081.604
F.01U.261.378

VGA-SBOX-COVER Cover for AUTODOME power supply box
Cover for AUTODOME Power Supply Boxes, white
Order number **VGA-SBOX-COVER | F.01U.010.505**
F.01U.247.808

VG4-SFPCKT Ethernet to SFP interface kit
Ethernet media converter video transmitter/data receiver fiber optic kit for AUTODOME cameras, for MIC-IP-PSU for MIC analog cameras and for the Surveillance cabinets (NDA-U-PA0, NDA-U-PA1 and NDA-U-PA2).
Order number **VG4-SFPCKT | F.01U.142.529**

SFP-2 Fiber module, multimode, 1310nm, 2LC
SFP Fiber Optic Module, 2 km (1.2 miles), 2 LC connectors.
Multi-mode
1310 nm
Order number **SFP-2 | F.01U.136.537**

SFP-3 Fiber module, single-mode, 1310nm, 2LC
SFP Fiber Optic Module, 20 km (12.4 miles), 2 LC connectors.
Single-mode
1310 nm
Order number **SFP-3 | F.01U.136.538**

SFP-25 Fiber module, 1310/1550nm, 1SC
SFP Fiber Optic Module, 2 km (1.2 miles), 1 SC connector
Multi-mode
1310/1550 nm
Order number **SFP-25 | F.01U.136.541**

SFP-26 Fiber module, 1550/1310nm, 1SC
SFP Fiber Optic Module, 2 km (1.2 miles), 1 SC connector
Multi-mode
1550/1310 nm
Order number **SFP-26 | F.01U.136.542**

VG4-A-PA0 Pendant arm, power box, 24VAC, AUTODOME
Pendant arm mount with power supply box for an AUTODOME Series camera, no transformer, white
Order number **VG4-A-PA0 | F.01U.009.671**
F.01U.081.560 F.01U.096.637 F.01U.097.435
F.01U.261.373

VG4-A-PA1 Pendant arm, power box, 120VAC, AUTODOME
Pendant arm mount with power supply box for an AUTODOME Series camera with a 120 VAC transformer, white
Order number **VG4-A-PA1 | F.01U.261.374**
F.01U.009.663 F.01U.081.571

VG4-A-PA2 Pendant arm, power box, 230VAC, AUTODOME
Pendant arm mount with power supply box for an AUTODOME Series camera with a 230 VAC transformer, white
Order number **VG4-A-PA2 | F.01U.009.664**
F.01U.081.582 F.01U.096.638 F.01U.097.431
F.01U.261.375

VGA-PEND-ARM Pendant arm with wiring, for AUTODOME
Compatible with an AutoDome Series pendant housing
Order number **VGA-PEND-ARM | F.01U.247.810**
F.01U.261.947

VGA-PEND-WPLATE Mounting plate for VGA-PEND-ARM
Mounting plate for VGA-PEND-ARM, compatible with an AutoDome Series camera
Order number **VGA-PEND-WPLATE | F.01U.247.809**

VGA-ROOF-MOUNT Roof parapet mount for AUTODOME series

Roof parapet mount, white

VG5-6xx/7xxx cameras require VG4-A-9543 Pipe Mount (sold separately).

NEZ-5130-/NEZ-5230- cameras require NDA-ADPTR-NPTMET (sold separately)

Order number **VGA-ROOF-MOUNT | F.01U.247.811**

LTC 9230/01 Parapet roof mount adapter

Flat Roof Mount Adapter for mounting a unit in an upright position on a flat surface.

Order number **LTC 9230/01 | F.01U.503.630**

VG4-A-9541 Pole mount adapter

Pole mount adapter for an AUTODOME pendant arm or a DINION imager, designed for poles with a diameter of 100-380 mm (4-15 in.), white

Order number **VG4-A-9541 | F.01U.123.433**

VG4-A-9542 Corner mount adapter for AUTODOME

Corner mount adapter for an AUTODOME pendant arm or a DINION imager

Order number **VG4-A-9542 | F.01U.123.434**

VG4-A-9543 Pipe mount for AUTODOME , white

Pipe mount, white, for an AutoDome Series pendant housing

Order number **VG4-A-9543 | F.01U.009.673**

VGA-BUBBLE-PCLA Bubble, pendant, clear

Low-impact acrylic bubble

Order number **VGA-BUBBLE-PCLA | F.01U.247.818**

VGA-BUBBLE-PTIA Bubble, pendant, tinted

Low-impact acrylic bubble

Order number **VGA-BUBBLE-PTIA | F.01U.247.820**

VGA-BUBBLE-IK10 Bubble, pendant, IK10-rated

IK10-rated bubble qualified for use with AUTODOME 7000 HD cameras with pendant housings

Order number **VGA-BUBBLE-IK10 | F.01U.315.882**

Services**EWE-AD7IIP-IW 12mths full wrty ext AD 7x00i Series**

12 months warranty extension

Order number **EWE-AD7IIP-IW | F.01U.382.507**

Represented by:**Europe, Middle East, Africa:**

Bosch Security Systems B.V.
P.O. Box 80002
5600 JB Eindhoven, The Netherlands
Phone: + 31 40 2577 284
emea.securitysystems@bosch.com
emea.boschsecurity.com

Germany:

Bosch Sicherheitssysteme GmbH
Robert-Bosch-Ring 5
85630 Grasbrunn
Germany
www.boschsecurity.com

North America:

Bosch Security Systems, LLC
130 Perinton Parkway
Fairport, New York, 14450, USA
Phone: +1 800 289 0096
Fax: +1 585 223 9180
onlinehelp@us.bosch.com
www.boschsecurity.us

Asia-Pacific:

Robert Bosch (SEA) Pte Ltd, Security Systems
11 Bishan Street 21
Singapore 573943
Phone: +65 6571 2808
Fax: +65 6571 2699
apr.securitysystems@bosch.com
www.boschsecurity.asia